

HANDBOOK  
OF THE  
18-PR. Q.F. GUN  

---

LAND SERVICE.  

---

(1918.)

(REPRINTED WITH AMENDMENTS 1914.)

# MILITARY BOOKS

Published by



Authority.

LONDON:

PRINTED UNDER THE AUTHORITY OF HIS MAJESTY'S STATIONERY OFFICE  
BY HARRISON AND SONS, 45-47, ST. MARTIN'S LANE, W.C.,  
PRINTERS IN ORDINARY TO HIS MAJESTY.

To be purchased, either directly or through any Bookseller, from  
WYMAN AND SONS, LTD., 29, BREAMS BUILDINGS, FETTER LANE, E.C., and  
54, ST. MARY STREET, CARDIFF; or  
H.M. STATIONERY OFFICE (SCOTTISH BRANCH), 23, FORTH STREET, EDINBURGH; or  
E. PONSONBY, LTD., 116, GRAFTON STREET, DUBLIN;  
or from the Agencies in the British Colonies and Dependencies,  
the United States of America and other Foreign Countries of  
T. FISHER UNWIN, LONDON, W.C.

(The prices in brackets are those at which the books are obtainable, post free, by Officers, Non-Commissioned Officers, and Men, in the manner prescribed by Appendix XXIII of the King's Regulations and Orders for the Army, 1912. Applications should be made on Army Form L. 1872, and addressed to the Secretary, War Office, S.W.)

- ABYSSINIA.** Expedition to. 2 vols. and maps. 1870. Half Mor., £5 5s. Cloth, £4 4s.
- AFRICA.** Continent of. Geology of. Notes on. 1906. 3s. (2s. 4d.)
- AMHARIC LANGUAGE.** Short Manual of the. With Vocabulary. 1909. 5s. (3s. 6d.)
- ANIMAL MANAGEMENT.** 1908. 1s. 6d. (1s. 4d.)
- ARABIC GRAMMAR.** Two parts. 1887. (Sold to Officers only). 10s. (10s. 6d.)
- ARMOURERS,** Instructions for, in the care, repair, browning, &c., of Small Arms, Machine Guns, "Parapet" Carriages, and for the care of Bicycles. 1912. 1s. 6d. (1s. 4d.)
- Ditto. Amendments. Aug. 1912; Aug. 1914. Each 1d. (1d.)
- ARMY ACCOUNTS.** (Reprinted from THE ARMY REVIEW, Jan. 1914). 3d. (3d.)
- ARMY CIRCULARS AND ARMY ORDERS** issued before Dec. 31, 1892, which are still in force and required for reference. Reprint of. May, 1896. 3d. (3d.)
- ARMY ORDERS.** Monthly. Each 3d. (3d.)
- ARMY ORDERS.** Covers for. 9d. (9d.)
- ARMY ENTRANCE Regulations:—**
- R.M. Academy. Admission to, from April 1, 1912. 1d. (1d.) (Under revision)
  - R.M. College. Ditto. 1d. (1d.) (Under revision)
  - Military Forces of the Self-governing Dominions and Crown Colonies. Officers of the. 1912. 1d. (1d.)
  - Militia and Imperial Yeomanry. Officers of. 1907. 1d. (1d.)
  - Special Reserve of Officers, Malta Militia, Bermuda Militia, Channel Islands Militia, and Territorial Force. Officers of the. 1912. 1d. (1d.)
  - University Candidates. 1912. 1d. (1d.)
  - Warrant Officers and N.C.O. of the Regular Army. Combatant Commissions as Second Lieutenants. 1914. Provisional. 1d. (1d.)
- See also Commission; Medical Corps; Special Reserve; Territorial Force; Veterinary Corps.
- ARMY LIST.** The Quarterly (not issued in October, 1914). Each 15s. (10s. 8d.)
- ARMY LIST.** Monthly. Each 1s. 6d. (1s. 5d.) (Not issued in September, 1914.)
- PROMOTIONS, APPOINTMENTS, &c.,** during August, 1914. (Printed in consequence of the temporary suspension of the Monthly Army List.) 6d. (6d.)
- Ditto, during September, 1914. (Ditto.) 6d. (7d.)
- ARMY PAY,** Appointment, Promotion, and Non-Effective Pay. Royal Warrant. 1914. 6d. (7d.)
- ARMY ALLOWANCES** Regulations. 1914. 6d. (6d.)
- ARMY REVIEW.** Quarterly. July 1911 to Oct. 1914. 1s. (Up to July 1914, 1s.; Oct. 1914, 11d.) (Publication suspended)
- ARMY SERVICE CORPS:—**
- Regimental Standing Orders. 1911. 6d. (6d.); Amendments. 1d. (1d.); A.S.C. Memorandum No. 25. 1d. (1d.)
  - Training. Part I. (Reprinted, with Amendments, 1914). 9d. (8d.) (In the press)
  - Ditto. Part II. Supplies. 1909. (Reprinted 1914, with new Appendix XII.) 1s. 3d. (1s. 1d.)
  - Ditto. Part III. Transport. 9d. (9d.)
  - Ditto. Part IV. Mechanical Transport. (Out of print)
  - Ditto. Amendments, July 1914, to Parts I. and III. 3d. (3d.)

(B 11226) Wt. 49470-640 10M 4/15 H & S

MILITARY BOOKS, published by Authority—continued.

(As to prices in brackets, see top of page 2.)

- ARTIFICERS.** Military. Handbook. 9th Edition. 1910. 1s. (11d.) (Under revision)
- Ditto. Amendments. 1912; May 1914. Each 1d. (1d.)
- ARTILLERY AT THE PICARDY MANGUVRES** in 1910. Translated from the French. 2s. 6d. (2s.)
- ARTILLERY,** Royal:—
- Officers' Mess Management. (See Ordnance College.)
  - Practice. Instructions:—
    - Garrison. Coast Defences. Seawards. 1914-15. 3d. (3d.)
    - Garrison. Siege and Movable Armament. 1914. 3d. (3d.)
    - Horse, Field, and Heavy. 1914. 6d. (6d.)
  - Standing Orders for:—
    - Brigade of Mounted Artillery. 1d. (1d.)
    - Lieut.-Colonel's Command, R.G.A. (Coast and Siege). 1d. (1d.)
  - Training:—
    - Field. 1914. 9d. (9d.)
    - Garrison.—
      - Vol. I. 1914. 6d. (6d.)
      - Vol. II. (Siege). 1911. (Reprinted, with Amendments, 1914). 9d. (8d.)
      - Vol. III. 1911. (Reprinted, with Amendments, 1914). 1s. (11d.)
- ARTILLERY COLLEGE.** Reports upon the 14th to 18th Senior Classes. Each 1s. (9d.) (See also Ordnance College.)
- ARTILLERY. FIELD.** The Tactics of. (Von Schell.) Translated. 1900. 1s. (10d.)
- ARTILLERY INSTRUMENTS.** Handbook of. 1914. 1s. 6d. (1s. 4d.)
- ARTILLERY MUSEUM** in the Rotunda, Woolwich. Official Catalogue. 1906. (Sold at the Rotunda. 1s. 6d.)
- ARTILLERY AND RIFLE RANGES ACT, 1885, and MILITARY LANDS ACTS, 1892 to 1903.** Byelaws under:—
- Aldeburgh, 1896; Ash (Aldershot Camp), 1887; Finborough, 1901; Hythe, 1894; Inchkeith Battery, 1896; Kinghornness, 1896; Landguard, 1887; Lydd—Dungeness, 1895; Middlewick, 1890; Millbrook, 1888; Orchard Portman, 1896; Scarborough, 1902; Scraps Gate, 1886; Shoeburyness, 1895; Southwold, 1896; Strensall, 1900; Wash, 1891; Whitehaven Battery (Cumberland), 1896; each 1d. (1d.)
  - Purfleet, 1911. 1s. (9d.)
  - Salisbury Plain, 1900. 4d. (4d.)
- ARTILLERY STORE ACCOUNTS AND THE SUPERVISION OF R.G.A. SUB-DISTRICTS.** Notes on. 1914. 1s. (10d.)
- ARTILLERY STORE ACCOUNTS AND THE CARE AND PRESERVATION OF EQUIPMENT OF ROYAL ARTILLERY, HORSE, FIELD, AND HEAVY BATTERIES.** Notes on. Sept. 1914. 6d. (5d.)
- BARRACKS.** Care of. Instruction in. 1901. 9d. (7d.)
- BASHFORTH CHRONOGRAPH.** Experiments with, to determine the resistance of the air to the motion of projectiles. Report on. 1870. 1s. (9d.)
- BAYONET FIGHTING.** Instruction with Service Rifle and Bayonet. 1915. 1d. (1d.)
- BAYONET FIGHTING FOR COMPETITIONS.** Instruction in. 1d. (1d.)
- BERMUDA MILITIA ARTILLERY** Regulations, 1914. 9d. (7d.)
- BICYCLES.** Military. Handbook on. 1911. (Reprinted, with Amendments, 1914). 1d. (1d.)
- BRITISH MINOR EXPEDITIONS, 1746 to 1814.** 1884. 2s. 6d. (1s. 11d.)
- CADET UNITS.** (See Territorial Force.)
- CAMEL CORPS TRAINING.** Provisional. 1913. 8d. (7d.)
- CAPE OF GOOD HOPE.** Reconnaissance Survey of the, 1908-1911. Report on the. 1s. 6d. (1s. 1d.)
- CAVALERIE.** Translated from the French of Captain Loir. (In the press)
- CAVALRY OF THE LINE. PEACE ORGANIZATION OF THE;** and Arrangements for Mobilization consequent on the establishment of Cavalry Depôts. (Special A.O., July 19, 1909). 1d. (1d.)
- CAVALRY SCHOOL, NETHERAVON.** Standing Orders. 1911. 2d. (2d.)
- CAVALRY TRAINING.** 1912. (Reprinted with Amendments, 1914.) 1s. (10d.) (In the press)
- CEREMONIAL.** 1912. 3d. (4d.); Provisional Amendments, June 1914. 1d. (1d.)
- CHEMISTRY. PRACTICAL.** Quantitative and Qualitative. A Course of. 5s. (3s. 8d.)
- CHEMISTS OF THE RESEARCH DEPARTMENT.** Rules and Regulations. 1d. (1d.)
- CHIROPODY.** Manual of. 2d. (2d.)
- CIVIL EMPLOYMENT FOR EX-SOLDIERS.** Guide to. 1913. 2d. (2d.)
- CIVIL EMPLOYMENT** Regulations. 1913. 1d. (1d.)
- CIVIL POWER. DUTIES IN AID OF THE.** Special A.O. Dec. 17, 1908. (Amendments to "King's Regulations" and to "Manual of Military Law"). 1d. (1d.)

(As to prices in brackets, see top of page 2.)

- CLOTHING AND NECESSARIES** (including Materials). Priced Vocabulary of 1913. 1s. (11d.)  
Ditto. Amendments, July, Oct. 1913; Jan., April, July 1914. Each 1d. (1d.)
- CLOTHING Regulations:—**  
Part I. Regular Forces (excluding the Special Reserve). 1914. 6d. (6d.)  
Part II. Special Reserve. 1914. 3d. (3d.)  
Part III. Mobilization, Field Service, and Demobilization. 1908. 3d. (3d.)  
Amendments to Parts I, II, and III. Nov. 1909; April, Oct. 1910; March, April, Sept., Nov. 1911; Feb., May, July, Sept. 1912; April, July 1913. Each 1d. (1d.)
- COLCHESTER GARRISON.** Standing Orders. 1913. 9d. (7d.)
- COMMAND. ALDERSHOT.** Standing Orders. 1914. 2s. 3d. (1s. 9d.)
- COMMAND. THE ART OF.** By Colonel von Spohn. Translated. 1d. (1d.)
- COMMAND. WESTERN.** Standing Orders. Jan. 1910. (Reprinted, with Amendments, 1915). 6d. (5d.)
- COMMANDS, Military, and Staff in the United Kingdom.** Reorganization of. (Special A.O., Jan. 6, 1906, with alterations to date. Issued with Special A.O., Nov. 11, 1907.) 3d. (3d.)
- COMMISSION IN H.M. REGULAR ARMY** (from 1st April, 1912). Short Guide to the various ways of obtaining a; &c., &c. April 1912. 2d. (2d.) (See also Army Entrance; Medical Corps; Special Reserve; Territorial Force; Veterinary Corps.)
- COMPANY TRAINING.** Notes on. For the use of the Special Reserve, Territorial Force, and newly-raised Units of the Regular Army. Sept. 1914. 1d. (1d.)
- CONVEYANCE OF TROOPS AND ISSUE OF TRAVELLING WARRANTS.** Instructions. 1910. 2d. (2d.)
- COOKING.** Military. Manual of. 6d. (5d.)
- COOKING AND DIETARY.** Military. Manual of. 1915. Mobilization. (In the press)
- COURSES OF INSTRUCTION, 1914-15.** 2d. (2d.)  
Ditto, at Practice Camps. 1914. 1d. (1d.)
- CREWS OF WAR DEPARTMENT VESSELS AND BOATS AT HOME STATIONS.** Regulations for the Appointment, Pay, and Promotion of. 1911. 2d. (2d.)
- CYCLIST TRAINING.** Provisional. 1914. 3d. (3d.)
- DIVISION ORDERS.** Extracts from. 1880. 2s. 6d. (1s. 9d.)
- DRAINAGE MANUAL.** 1907. 2s. 6d. (2s.)
- DRAWING PLATES.** Military:—  
Attack of Dufour's Countermine or 2nd plate of Mines; Carnot's First System; Detached Forts; Concealed Defences, 1, 2, 3, 4; Printing Plate, A, B, C, &c.; Detail Plate, No. 1; Do., No. 2; Neighbourhood of Woolwich; Village and Surrounding Ground. Each 2d. (2d.)  
Attack of Fortress—Preliminary Operations; Do., Distant Attack; Do., Close Attack; Neighbourhood of Metz. Each 3d. (3d.)  
Woods and Villages. 6 plates. Each 6d. (5d.)  
Neighbourhood of Woolwich. Southern Side. 1s. 6d. (1s. 1d.)
- DRESS REGULATIONS.** 1911. 2s. 6d. (2s.)  
Ditto. Amendments. March, Aug. 1912. Each 1d. (1d.); Aug. 1913. 2d. (2d.)
- DRUM AND FLUTE DUTY** for the Infantry, with Instructions for the Training of Drummers and Flautists. 1887. 2s. (1s. 6d.)
- DYNAMICS.** Notes on. (See Ordnance College.)
- EGYPT. BRITISH FORCE IN.** Standing Orders. 1912. 1s. (10d.)
- EGYPT. CAMPAIGN OF 1882 IN.** Military History. With Case of Maps. Condensed Edition. 1908. 3s. 6d. (2s. 8d.)
- ELECTRICAL COMMUNICATIONS. FIXED.** Instructions as to. 1912. 4d. (4d.)
- ELECTRICITY AND MAGNETISM.** Text Book for the use of the Cadets at the R.M. Academy. 1911. 2s. 6d. (2s.)
- ELECTRICITY.** Notes on. 1911. 1s. 3d. (1s. 1d.)
- ELECTRIC LIGHT APPARATUS. DEFENCE.** Instructions for the Working of. 1911. 1d. (1d.)
- ELECTRIC LIGHTING.** Military. Vol. I. 1s. (11d.); Vol. II. (Reprinted, with Amendments, 1915). (In the press); Vol. III. 1s. (11d.)
- ENCOUNTER. THE BATTLE OF.** By Hans von Kiesling. Part I. Practical. Translated. 1s. 6d. (1s. 3d.)
- ENGINEER SERVICES** Regns. Peace:—  
Part I. 1910. 1s. (10d.)  
Part II. 1911. Technical Treatises. 9d. (7d.)
- ENGINEER TRAINING.** 1912. (Reprinted, with Amendments, 1914). 6d. (6d.)
- ENGINEERING.** Field. Manual of. 1911. 9d. (9d.)
- ENGINEERING.** Military:—  
Part I. Field Defences. 1908. 1s. 6d. (1s. 3d.)  
Part II. Attack and Defence of Fortresses. 1910. (Reprinting)  
Part IIIa. Military Bridging—General Principles and Materials. 1913. 1s. (11d.)  
Part IIIb. Ditto—Bridges. 1s. 3d. (1s. 2d.)  
Part IV. Mining and Demolitions. 1910. 1s. (11d.)  
Part V. Miscellaneous. 1914. 1s. (11d.)  
Part VI. Military Railways. 1898. (Out of print)

(As to prices in brackets, see top of page 2.)

**EQUIPMENT. INFANTRY.** Pattern 1908 Web. 1913. 2d. (2d.)**EQUIPMENT Regulations:—**

Part I. 1912. (Reprinted, with Amendments published in Army Orders up to Aug. 31, 1914). 1s. (11d.)

## Part 2. Details—

- | Secs.              |  | Secs. |  |
|--------------------|--|-------|--|
| I.                 | Infantry. (Regular Army.) 1913. 6d. (5d.)  | Xm.   | Bridging Train. (Regular Army.) 1912. 2d. (2d.)  |
| Ia.                | Mounted Infantry. 1912. 6d. (5d.)  | Xn.   | Field Squadron. (Regular Army.) 1914. 2d. (2d.)  |
| II.                | Cavalry. (Regular Army.) 1914. 3d. (3d.)   | XIa.  | Horse Artillery. Q.F. 13-pr. 1913. 9d. (8d.)   |
| III.               | Army Service Corps. (Regular Army.) 1913. 6d. (5d.)  | XIb.  | Field Artillery. Q.F. 18-pr. (Regular Army.) 1914. 9d. (8d.)   |
| IV., IVa, and IVb. | Army Ordnance Corps. Army Pay Corps Army Veterinary Corps. (Regular Army.) 1914. 2d. (2d.)   | XIc.  | Field Artillery. Q.F. 4.5-in. Howitzer. (Regular Army.) 1913. 9d. (8d.)  |
| V.                 | Royal Army Medical Corps. (Regular Army.) 1914. 2d. (2d.)  | XId.  | Reserve Brigades with Q.F. 18-pr. Equipment, Horse and Field Artillery, Staff and Depôts, Riding Establishment, School of Gunnery (Horse and Field), and Mounted Band. (Regular Army.) 1914. 6d. (6d.) |
| VI.-IX.            | R.M. Academy; R.M. and Staff Colleges; Garrison Staff and Schools of Instruction; Military Prisons, Detention Barracks and Military Provost Staff Corps. (Regular Army.) 1914. 2d. (2d.) | XIe.  | Mountain Artillery with B.L. 2.75-in. Equipment, Mountain Battery and Ammunition Column, Mule Transport. Provisional. (Regular Army.) 1914. 6d. (5d.)  |
| Xa.                | Engineer. General. Fortress, Survey, Railway, and Depot Units. Peace and War. (Regular Army.) 1914. 2d. (2d.)  | XIIa. | Royal Garrison Artillery. (Regular Army.) 1914. 2s. 6d. (1s. 11d.)   |
| Xb.                | Field Troop. (Regular Army.) 1912. 2d. (2d.)   | XIIb. | Royal Garrison Artillery, Siege Artillery, Movable Armament and Machine Guns in Armaments. 1913. 1s. (10d.)  |
| Xc.                | Field Company. (Regular Army.) 1914. 2d. (2d.)   | XIIc. | Heavy Artillery. B.L. 60-pr. (Regular Army.) 1913. 9d. (8d.)   |
| Xd.                | Divisional Signal Company. (Regular Army.) 1914. 2d. (2d.)   | XIV.  | Cavalry School, Netheravon. (Regular Army.) 1914. 2d. (2d.)  |
| Xe.                | Signal Company (Wireless). (Regular Army.) 1912. 2d. (2d.)   | XV.   | Camel Corps School, Egypt. (Regular Army.) 1914. 2d. (2d.)   |
| Xf.                | Headquarters, Signal Units. (Regular Army.) 1914. 2d. (2d.)  | XVI.  | Special Reserve. 1913. 4d. (4d.)   |
| Xg.                | Signal Company (Cable). (Regular Army.) 1912. 2d. (2d.)  | XVII. | Officers Training Corps. 1912. 3d. (3d.)   |
| Xh.                | Signal Squadron. (Regular Army.) 1914. 2d. (2d.)   |       | Practice Batteries and Drill Guns (Fixed Mountings) of the Royal Garrison Artillery. (Part 2, Secs. XIIa. and XVI., and Part 3.) 1909. 1s. 6d. (1s. 2d.)   |
| Xj.                | Signal Troop with Cavalry Brigade. (Regular Army.) 1912. 2d. (2d.)   |       |  |
| Xk.                | Signal Troop with a Cavalry Brigade not allotted to a Cavalry Division. (Regular Army.) 1914. 2d. (2d.)  |       |  |
| Xl.                | Signal Company (South Africa). (Regular Army.) 1912. 2d. (2d.)   |       |  |

Part 3. Territorial Force. 1914. 6d. (6d.)

Ditto. Details:—

Sec. IX. Artillery. 1912. 1s. (9d.)

Ditto. Amendments. April, 1912; Feb. 1914. Each 1d. (1d.)

Sec. X. Engineer. 1912. 3d. (3d.)

Amendments to Part 2. Feb., April, July (two issues), Aug. 1914. Each 1d. (1d.)

Amendments to Parts 1, 2, and 3. Nov. 1913. 1d. (1d.)

Amendments to Parts 1, 2, and 3. March, July 1913; April, Aug. 1914. Each 2d. (2d.)

(As to prices in brackets, see top of page 2.)

## ESTABLISHMENTS:—

## PEACE:—

- Part II. Territorial Force. 1913-14. 4*d.* (4*d.*) (Under revision)  
 Ditto. Changes in. Nov. 1913. 1*d.* (1*d.*)  
 Part III. Departmental and Miscellaneous Regular Establishments and Instructional Institutions. 1913-14. 2*d.* (2*d.*)  
 Part IV. Headquarters Establishments, Home, Colonies and India. 1913-14. 3*d.* (3*d.*)  
 Part V. Establishment of Commands Abroad and Summaries of the Military Forces of the Crown. 1913-14. 2*d.* (2*d.*)

## WAR:—

- Part I. Expeditionary Force. 1914. 8*d.* (8*d.*) (Under revision)  
 Part II. Territorial Force. 1911. 8*d.* (7*d.*)  
 Part V. Reserve, Depot, and other Regimental Units maintained at Home after Mobilization. 1914. 4*d.* (4*d.*)  
 Part VI. Departmental and Miscellaneous Regular Establishments and Instructional Institutions maintained at Home after Mobilization. 1914. 2*d.* (2*d.*)  
 New Armies. 1915. 2*d.* (In the press)

**EUROPEAN WAR, 1914-15.** Despatches (Naval and Military) relating to Operations in the War. Sept., Oct., and Nov. 1914. With List of Honours and Rewards conferred. With Sketch Map. 2*d.* (3*d.*)

## EXAMINATION PAPERS:—

- Qualifying Certificates. Sept. 1905; March 1906; Sept. 1909; March, Sept. 1910; March, Sept. 1911; March 1912. Each 6*d.* (5*d.*)  
 Entrance: R.M. Academy, R.M. College, Qualifying Test for Commissions. Supplementary First Appointments in the Royal Marines. June-July 1912. 1*s.* (11*d.*)  
 Entrance: R.M. Academy, R.M. College, Qualifying Test for Commissions. Nov. 1912; Nov.-Dec. 1913. Each 1*s.* (11*d.*)  
 Entrance: R.M. Academy, R.M. College, Qualifying Test for Commissions. Supplementary First Appointments in the Royal Marines. Appointments in the Indian Police Force. Appointments in the Police Forces of the Straits Settlements and the Federated Malay States. Cadetships in the Royal Navy (Special Entry). June-July 1914. 1*s.* (11*d.*)  
 Entrance: R.M. Academy, R.M. College. Nov.-Dec. 1914. 1*s.* (10*d.*)  
 Freehand Drawing at the Army Entrance Examination of Nov. 1913. Specimen Paper to illustrate the kind of questions that will be set in. 6*d.* (5*d.*)  
 R.M. Academy, Fourth Class; R.M. College, Fourth, Third, and Second Divisions. July, Dec. 1904; June 1905. Each 1*s.*  
 R.M. Academy, Fourth Class; R.M. College, Senior Division. Dec. 1905; June, Dec. 1906; July, Dec. 1907. Each 1*s.*  
 Staff College. Admission. Aug. 1907; Aug. 1909; July 1911; June-July 1912; June-July 1913. Each 1*s.* (6*d.*)  
 Regular Forces, Canadian Permanent Forces, Special Reserve of Officers, Territorial Force, and Colonial Military Forces. May, Nov. 1906; May, Nov. 1908. Each 1*s.* (11*d.*)  
 Ditto. May 1909. 9*d.* (8*d.*)  
 Officers for Promotion. Dec. 1912; May, Dec. 1913; April 1914. Each 1*s.* (6*d.*)  
 Militia, Imperial Yeomanry, and University Candidates. March, Sept. 1904; Sept. 1905; Oct. 1906. Each 1*s.*  
 Special Reserve, Militia, Territorial Force, and University Candidates. Oct. 1911; March, Oct. 1912; March, Oct. 1913. Each 1*s.* (6*d.*)  
 Special Reserve, Militia, Territorial Force, Non-Commissioned Officers, and University Candidates. March 1914. 1*s.* (6*d.*)  
 Officers Training Corps:—  
 Cadets of the Senior Division. Certificate A. Dec. 1908. 6*d.* (5*d.*)  
 Cadets of the Junior and Senior Divisions. Certificates A and B. Spring of 1909; Nov. 1910; May, Nov. 1911; March, Nov. 1912; March, Nov. 1913; March 1914. Each 6*d.* (6*d.*)  
 Foreign Languages. Modern. July 1906; July 1908; April, July 1909; Jan., June, Oct. 1910; Jan., June, Oct. 1911; June 1912; June 1913; June 1914. Each 1*s.* (6*d.*)

**EXPLOSIVES.** Service. Treatise on. 1907. 1*s.* 6*d.* (1*s.* 2*d.*)

**FIELD ALMANAC.** 1915. 1*d.* (2*d.*)

## FIELD SERVICE. Manual for:—

- Artillery. Field. Brigade. Q.F. 18-pr. 1908. 3*d.* (3*d.*) (Under revision)  
 Ditto. Ditto. (Howitzer) Brigade. 5-inch R.L. 1908. 3*d.* (3*d.*)  
 Ditto. Heavy (B.L. 60-pr.) Battery and Ammunition Column. Expeditionary Force. 1910. 3*d.* (3*d.*)

(As to prices in brackets, see top of page 2.)

## Field Service. Manual for—continued.

- Artillery. Horse. Brigade. 13-pr. Q.F. 1908. 3*d.* (3*d.*) (Under revision)  
 Ditto. Ditto. Appendix to. R.H.A. Battery and Mounted Brigade Ammunition Column. 1*d.* (1*d.*)  
 Cavalry Regiment. Expeditionary Force. 1913. 3*d.* (3*d.*) (Under revision)  
 Engineers. Balloon Company. Expeditionary Force. 1910. 3*d.* (3*d.*)  
 Ditto. Bridging Train. Expeditionary Force. 1915. 3*d.* (3*d.*) (In the press)  
 Ditto. Field Company. Expeditionary Force. 1915. 3*d.* (3*d.*) (In the press)  
 Ditto. Field Squadron. Expeditionary Force. 1914. 3*d.* (3*d.*)  
 Ditto. Field Troop. Expeditionary Force. 1910. 3*d.* (3*d.*)  
 Ditto. Works Company. Expeditionary Force. 1910. 3*d.* (3*d.*)  
 Headquarters Units. Expeditionary Force. 1911. 3*d.* (3*d.*)  
 Infantry Battalion. Expeditionary Force. 1914. 3*d.* (3*d.*)  
 Infantry (Mounted) Battalion. Expeditionary Force. 1913. 3*d.* (3*d.*)  
 Medical Service. Army. Expeditionary Force. 1914. 3*d.* (3*d.*)  
 Signal Service. Signal Company (Air-Line). Expeditionary Force. 1913. 3*d.* (3*d.*)  
 Ditto. Ditto. (Cable). Expeditionary Force. 1913. 3*d.* (3*d.*)  
 Ditto. Ditto. (Divisional). Expeditionary Force. 1915. 3*d.* (3*d.*) (In the press)  
 Ditto. Ditto. (Lines of Communication). Expeditionary Force, 1914. 3*d.* (3*d.*)

**FIELD SERVICE POCKET BOOK.** 1914. 1*s.* (11*d.*)

## FIELD SERVICE REGULATIONS:—

- Part I. Operations. 1909. (Reprinted, with Amendments, 1914). 6*d.* (6*d.*)  
 Part II. Organization and Administration. 1909. (Reprinted, with Amendments to Oct. 1914). 1*s.* (10*d.*)

## FINANCIAL INSTRUCTIONS IN RELATION TO ARMY ACCOUNTS.

1910. (Reprinted, with Amendments to Sept. 1, 1914). 4*d.* (4*d.*)

## FLYING CORPS. ROYAL. Training Manual:—

- Part I. Provisional. 1914. 1*s.* (10*d.*)  
 Ditto. Amendments. Jan. 1915. 1*d.* (1*d.*)  
 Part II. Military Wing. Provisional. 1914. 3*d.* (4*d.*)

FOREIGN LANGUAGES. STUDY OF. Regulations. 1913. 2*d.* (2*d.*)FORTIFICATION. PERMANENT. For the Imperial Military Training Establishments and for the Instruction of Officers of all Arms of the Austro-Hungarian Army. 7th Edition. Translated. 4*s.* (2*s.* 11*d.*)FRANCO-GERMAN WAR, 1870-71. Translated from the German Official Account. Five vols. £6 11*s.* 6*d.*

Also separately, in Volumes in cloth, Sections in paper covers, and Plans unmounted:—

- First Part—History of the War to the Downfall of the Empire—  
 Vol. 1 (Secs. 1 to 5). Outbreak of Hostilities to Battle of Gravelotte. £1 6*s.* (Out of print)  
 Vol. 2 (Secs. 6 to 9). Battle of Gravelotte to Downfall of the Empire. £1 2*s.* (Out of print)

- Second Part—History of the War against the Republic—  
 Vol. 1 (Secs. 10 to 13). Investment of Paris to Re-occupation of Orleans by the Germans. £1 6*s.* (18*s.* 6*d.*)  
 Vol. 2 (Secs. 14 to 18). Events in Northern France from end of Nov. In North-west from beginning of Dec. Siege of Paris from commencement of Dec. to the Armistice. Operations in the South-east from middle of Nov. to middle of Jan. £1 6*s.* (19*s.*)  
 Vol. 3 (Secs. 19 and 20). Events in South-east France from middle of Jan. to Termination of Hostilities. Rearward Communications. The Armistice. Homeward March and Occupation. Retrospect. £1 11*s.* 6*d.* (£1 2*s.* 3*d.*)

## Section.

- Events in July. Plan. 3*s.* (2*s.* 2*d.*)
- Events to Eve of Battles of Wörth and Spicheren. 3rd Edition. 3*s.* (Out of print)
- Battles of Wörth and Spicheren. 3rd edition. 5*s.* (Out of print)
- Advance of Third Army to the Moselle, &c. 2nd Edition. 4*s.* (Out of print)
- Operations near Metz on 15th, 16th, and 17th August. Battle of Vionville—Mars la Tour. 2nd Edition. 6*s.* 6*d.* (Out of print)
- Battle of Gravelotte—St. Privat. 5*s.* (Out of print)
- Advance of Third Army and of Army of the Meuse against Army of Chalons. 6*s.* (Out of print)
- Battle of Sedan. 3*s.* (Out of print)
- Proceedings on German Coast and before Fortresses in Alsace and Lorraine. Battle of Noisseville. General Review of War up to September. 4*s.* 6*d.* (3*s.* 4*d.*)

(As to prices in brackets, see top of page 2.)

**Franco-German War—continued.**

Section.

10. Investment of Paris. Capture of Toul and Strassburg. 6s. (4s. 6d.)
11. Events before Paris, and at other points of Theatre of War in Western France until end of October. 5s. 3d. (3s. 11d.)
12. Last Engagements with French Army of the Rhine. Occurrences after fall of Strassburg and Metz to middle of November. 4s. 6d. (3s. 5d.)
13. Occurrences on Theatre of War in Central France up to Re-occupation of Orleans by the Germans. 6s. (4s. 6d.)
14. Measures for Investment of Paris up to middle of December. 4s. (3s.)
15. Measures for Protecting the Investment of Paris and Occurrences before French Capital to commencement of 1871. 2s. 6d. (1s. 11d.)
16. Proceedings of Second Army from commencement of 1871 until the Armistice. 3s. 6d. (2s. 8d.)
17. Proceedings of First Army from commencement of 1871 until the Armistice. 3s. (2s. 3d.)
18. Occurrences on South-eastern Theatre of War up to middle of January, 1871. Events before Paris from commencement of 1871 to the Armistice. 8s. (6s.)
19. Occurrences on South-eastern Theatre of War from middle of January, 1871. Proceedings in rear of German Army and in Coast Provinces, from Nov. 1870 until the Armistice. 13s. 6d. (9s. 8d.)
20. General Retrospect of War from beginning of Sept., 1870, to Cessation of Hostilities. Armistice and Peace Preliminaries. Return of German Army and Peace of Frankfurt. The Occupation. The Telegraph, Post, Supply of Ammunition, Commissariat, Hospital Service, Divine Service, Military Justice, Recruitment, and Home Garrisons. Results. 5s. (3s. 9d.)

Analytical Index. 1s. 6d. (1s. 1d.)

Plans—

4. Battle of Colombey-Nouilly. 3d. (3d.)
  - 5A. Battle of Vionville—Mars la Tour. Position of Contending Forces at Noon. 3d. (3d.)
  - 5B. Battle of Vionville—Mars la Tour. Position of Contending Forces from 4 to 5 p.m. 3d. (3d.)
  - 9A. Battle of Sedan. Position of Contending Forces towards Noon. 3d. (3d.)
  - 9C. Battle of Sedan. Position of the Germans in the afternoon shortly before the end of the struggle. 3d. (3d.)
- (See also SIEGE OPERATIONS.)

- GERMAN ARMY.** Cavalry. Drill Regulations. 1909. 3d. (3d.)  
 Ditto. Field Service Regulations. 1909. 1s. (10d.)  
 Ditto. Foot Artillery. Drill Regulations. Part IV. THE FIGHT. 1909. 3d. (3d.)  
 Ditto. Manœuvres Regulations. 1908. 3d. (3d.)

- GERMANY.** The Campaign of 1866 in. With 22 Plans in portfolio. 1872. (Reprinted 1907.) 6s. (4s. 10d.)  
 Ditto. Moltke's Projects for. 1s. (10d.)

- GUERNSEY AND ALDERNEY ROYAL MILITIA.** Regulations. With the Militia Laws relating to the Islands. Provisional. 3s. (2s. 2d.)

**GUNS.** Drill for. (And see GUNS. Handbooks for):—

- 60-pr. B.L. 1912. 1d. (1d.)
- 18-pr. Q.F. 1914. 1d. (1d.)
- 15-pr. B.L. 1914. 1d. (1d.)
- 15-pr. B.L.C. 1914. 1d. (1d.)
- 15-pr. Q.F. 1912. 1d. (1d.)
- 13-pr. Q.F. 1914. 1d. (1d.)
- 12-pr. 12-cwt. Q.F. Land Service. 1914. 1d. (1d.)
- 10-pr. B.L. 1914. 1d. (1d.)
- 9·2-inch B.L. Mark IX, on Mark IV. Mounting. Land Service. 1914. 1d. (1d.)
- 9·2-inch B.L. "C" Mark IX, on Marks V<sup>A</sup>. and V<sup>B</sup>. Mountings. Land Service. 1914. 1d. (1d.)
- 9·2-inch B.L. Marks X., X<sup>v</sup>., and X<sup>s</sup>., on Mark V. Mounting. Land Service. 1914. 1d. (1d.)
- 6-inch B.L. Marks VII. and VII<sup>v</sup>. Land Service. 1914. 1d. (1d.)
- 6-inch B.L. Howitzer. 1912. (Reprinted, with Amendments to Dec. 1914.) 1d. (1d.)
- 6-inch Q.F. Land Service. 1914. 1d. (1d.)
- 5-inch B.L. Howitzer. 1912. (Reprinted 1914 with Amendments). 1d. (1d.)
- 4·7-inch Q.F., on Travelling Carriages. 1912. 1d. (1d.)
- 4·7-inch Q.F. Fixed Armament. Land Service. 1914. 1d. (1d.)
- 4·7-inch Q.F. Heavy Batteries. Provisional. 1914. 1d. (1d.)
- 4·5-inch Q.F. Howitzer. 1914. 1d. (1d.)
- 4-inch Q.F. Land Service. 1914. 1d. (1d.)
- 2·95-inch Q.F. 1914. 1d. (1d.)

40  
 W.O.  
 1795

# HANDBOOK

OF THE

# 18-PR. Q.F. GUN.

## LAND SERVICE.

1913.

(Reprinted, with Amendments, 1914.)



LONDON:

PRINTED UNDER THE AUTHORITY OF HIS MAJESTY'S STATIONERY OFFICE  
 BY HARRISON AND SONS, 45-47, ST. MARTIN'S LANE, W.C.,  
 PRINTERS IN ORDINARY TO HIS MAJESTY.

To be purchased, either directly or through any Bookseller, from  
 WYMAN AND SONS, LTD., 29, BREAMS BUILDINGS, FETTER LANE, E.C., and  
 54, ST. MARY STREET, CARDIFF; or  
 H.M. STATIONERY OFFICE (SCOTTISH BRANCH), 23, FORTH STREET, EDINBURGH; or  
 E. PONSONBY, LTD., 116, GRAFTON STREET, DUBLIN;  
 or from the Agencies in the British Colonies and Dependencies,  
 the United States of America, the Continent of Europe and Abroad of  
 T. FISHER UNWIN, LONDON, W.C.

Price One Shilling.

## CONTENTS.

	PAGE.
<b>Gun—</b>	
Description of .. .. .	5
Breech mechanism. . . . .	6
Firing .. .. .	7
Extractor .. .. .	7
Dummy breech screw and firing pin .. .. .	8
Instructions for removing and replacing breech fittings .. .. .	8
Separate demandable stores .. .. .	9
Care and preservation of gun and fittings .. .. .	10
<b>Carriage—</b>	
Description of .. .. .	11
Trail .. .. .	11
Cradle .. .. .	12
Hydraulic buffer and running out springs .. .. .	12
<b>Gear—</b>	
Clamping .. .. .	12
Elevating and range .. .. .	13
Traversing .. .. .	13
Firing .. .. .	14
Brake .. .. .	14
Shield .. .. .	14
Axletree and wheels .. .. .	15
<b>Sighting—</b>	
Sight, rocking bar .. .. .	16
Telescope, sighting, No. 4 .. .. .	17
Dial sight, No. 1 .. .. .	17
"    "    No. 7 and carrier .. .. .	18
Care and preservation of No. 7 dial sight and carrier .. .. .	20
Instructions for testing and adjusting the sights .. .. .	20
Indicator, fuze .. .. .	23
<b>Limbers—</b>	
Carriage .. .. .	24
Wagon .. .. .	25
<b>Wagons—</b>	
Ammunition .. .. .	25
G. S. .. .. .	28
Telephone .. .. .	29
Dimensions, weights, &c. .. .. .	26
Separate demandable stores .. .. .	27
Care and preservation of carriage, &c. .. .. .	31
Lubricating holes—Particulars of .. .. .	31
<b>Ammunition—</b>	
Table of .. .. .	32
Cartridge, shrapnel .. .. .	33
Primer .. .. .	33
Cartridge, shell star .. .. .	34
"    blank L.G. .. .. .	35
"    smokeless blank .. .. .	35
Fuzes, T and P, No. 80 .. .. .	36
"    time, No. 25 .. .. .	37
Clip, cartridge .. .. .	38
Implements, ammunition .. .. .	38
<b>Packing—</b>	
List of stores .. .. .	39
Diagrams .. .. .	45

(B11226) Wt. 49470—640 10000 4/15 H & S  $\frac{P 12}{400}$  (S)

## PLATES.

Gun (Marks I, I* and II) .. .. .	I
Breech mechanism .. .. .	II
Striker .. .. .	III
Lanyard, firing .. .. .	IV
Carriage .. .. .	V and VI
Hydraulic buffer and spring case .. .. .	VII
Elevating and range gear .. .. .	VIII
Traversing gear .. .. .	IX
Brake gear .. .. .	X
Rocking bar sight and sight, clinometer .. .. .	XI
Dial sight, No. 7 (2 plates) .. .. .	XII and XIII
Target, testing sight .. .. .	XIV
Fuze indicator, Mark II .. .. .	XV
Limber, carriage, side view .. .. .	XVI
"    "    end view .. .. .	XVII
"    "    wagon side view .. .. .	XVIII
"    "    end view .. .. .	XIX
Ammunition wagon, side view .. .. .	XX
"    "    rear view .. .. .	XXI
Telephone wagon, body and limber .. .. .	XXII
"    "    limber .. .. .	XXIII
Cartridge and shell (and Mark IV fuze) .. .. .	XXIV
Primer .. .. .	XXV
Fuze, time and percussion, No. 80, Mark IV .. .. .	XXVI

N.B.—This book is corrected up to February, 1913. Any alterations which may be suggested should be forwarded direct to Chief Inspector, Royal Arsenal, Woolwich

## AMENDMENTS TO Q.F. 13 AND 18-PR. HANDBOOKS.

Page 31.—Insert the following after line 2.

### CARRIAGE.

(Plates VII to XI.)

To remove the hydraulic buffer and springs (gun in position), Plate VII:—

NOTE.—Care should be taken that no one is standing in front of the carriage while the operation is being carried out.

1. Place the gun at depression and remove the outer nut (E) securing buffer cylinder, which will allow the cylinder to bear against the outer spring case cap (A).

2. Attach the "Apparatus, adjusting running out springs," to the controlling plunger (M), and take up the tension on the running out springs.

3. Remove the piston rod nut (G), the outer spring case cap (A), and filling plug (L).

4. Unscrew gradually the actuating nut of the apparatus and the inner nut (F) securing buffer cylinder (C) as the springs are released, care being taken when removing the cylinder that the filling hole is kept upright to prevent loss of oil.

To replace the hydraulic buffer and springs:—

1. Slightly depress the gun. Replace the rear washer (R) at the end of the outer spring case with radius to the rear, and insert three of the outer springs, and parting plates (J), in correct order.

LONDON:

PRINTED UNDER THE AUTHORITY OF HIS MAJESTY'S STATIONERY OFFICE  
BY HARRISON AND SONS, 45-47, ST. MARTIN'S LANE, W.C.,  
PRINTERS IN ORDINARY TO HIS MAJESTY.

To be purchased, either directly or through any Bookseller, from  
WYMAN AND SONS, LIMITED, 29, BREAMS BUILDINGS, FETTER LANE, E.C., and  
54, ST. MARY STREET, CARDIFF; or  
H.M. STATIONERY OFFICE (SCOTTISH BRANCH), 23, FORTH STREET, EDINBURGH; or  
E. PONSONBY, LIMITED, 116, GRAFTON STREET, DUBLIN;  
or from the Agencies in the British Colonies and Dependencies,  
the United States of America and other Foreign Countries of  
T. FISHER UNWIN, LIMITED, LONDON, W.C.

1915

Price One Penny.

2. Insert the inner spring case (B), with front washer (P) (radius to the front) and one outer spring in position.

3. Place an inner spring with the rear washer (T) in the inner spring case (radius to the rear), and insert two more inner springs with parting plates (K) in the correct position.

4. Place the front washer (S) (radius to the front), and the remaining inner spring on the buffer cylinder (C).

5. Attach the screw of the "Apparatus, running out springs," to the plunger (M).

6. Replace the cylinder, care being taken that the filling hole is at the top and that the inner nut (F) securing cylinder is passed on to the screw of the apparatus before the latter enters the lug of the gun. Replace the outer spring case cap (A) and piston rod nut (G) on piston rod (first seeing that the split pin (H) retaining stuffing-box stud, is placed in position and the point opened), care being taken to ensure that the featherway (a) in the cap engages the feather on the end of the piston rod (N).

7. Compress the springs, care being taken that the feathers on the end of the cylinder are in the correct position to enter the featherways in the lug of the gun, and that the inner nut (F) securing cylinder is correctly secured by screwing it up while compressing the springs.

8. Screw on the cap (A), remove the apparatus, replace the outer nut (E) securing cylinder, and the filling plug (L).

*In removing and replacing the buffer cylinder, the gun must be kept at depression or properly secured.*

NOTE.—If during firing it is found that the gun will not return to the firing position and remains practically at full recoil, then the inner spring case will have broken. In this case, special precautions will have to be taken when removing the buffer and springs, and are as follows :—

1. Place the gun at depression and run it back to a distance of about 43 ins. from the cradle, the breech being supported on the trail on skidding.

2. The piston rod nut (G) should *not* be removed.

3. Secure a rope to the lug on the breech ring of the gun and man it towards the rear by four men. This will remove the pressure of the outer springs from the threads of the cap on the outer spring case. While the rope is manned, unscrew the cap (A), taking care to keep clear of the muzzle.

4. Ease up the pull on the check rope, and allow the gun to run up gradually; at the same time, the motion should be assisted by

relieving the weight of the gun at the rear. The outer springs will then have extended to their normal condition.

5. Remove the piston rod nut, cap, the front broken portion of inner spring case and one outer spring, care being taken not to bend the piston rod. Remove filling plug and the plunger controlling, so as to empty the buffer. Then push the piston rod back into position and replace control plunger.

6. The inner springs and the remaining outer springs can be removed by attaching the "Apparatus, adjusting springs," and the remaining operations are similar to those before detailed, except that when the inner nut is removed the initial compression of the inner springs will force the gun to the rear about 10 ins.—and a light drag rope should be used to prevent this.

*To tighten, or renew the packing :—*

If any leakage of oil takes place at the gland, the packing should be tightened; if this will not stop the leak, the packing must be renewed.

*To tighten the packing (gun in position) :—*

1. Remove the piston rod nut (G), and outer spring case cap (A).

2. Screw up the gland (D) with the spanner (No. 121 for 13-pr., or No. 122 for 18-pr.). While in use the spanner must be kept against the face of the gland in order to disengage the retaining stud. The position of the gland after screwing up must permit of the retaining stud re-engaging with a slot in the gland.

3. Replace spring case cap and piston rod nut, taking care that the feather on the piston rod, and the featherway in the cap, are properly engaged.

*To renew the packing ring in the stuffing-box (gun in position) :—*

1. Empty the cylinder at the controlling plunger (M), and replace the plunger.

2. Unscrew the cap, leaving it on the piston rod, and draw it clear to the front. Then unscrew the gland and withdraw the outer ring supporting packing with the tools supplied, and replace the packing with fresh material, using the metal collar of the packing tools to assist the packing ring over the shoulder of the piston rod. Replace the supporting ring, gland and cap, and refill the buffer.

NOTE.—If the gun is not in position, the "Apparatus, adjusting running-out springs" must be attached to the control plunger before the cap is removed.



of the eccentric being to the front, and both in the same relative positions on the spindle, so as to engage the bearing on the cradle at the same time.

*Pin, locking shield pawl.*—It should be carefully noted that this pin is always in proper position when travelling.

*Wheels, Nos. 43 and 45.*—These wheels are fitted with dust caps, which can be removed with a No. 93 spanner; lateral play between end of pipe box and lynch pin can be adjusted by means of an adjusting collar with slots, through which the lynch pins pass; the slots vary in depth from .2 in. to .5 in., the difference in depth between each slot allows for a wear of .05 in.

A lynch pin of a capped wheel with the adjusting collar can be used with any ordinary second class wheel, if required.

An ordinary second class lynch pin and a second class "C" drag washer can be used on an emergency, with a capped wheel, if the cap be removed.

*Sights.*—Great care must be taken not to damage the sights when removing or replacing. The parts of the carriage to which the sights are attached must be absolutely clean and free from burrs.

*Deflection screw and nut.*—Should be kept free from grit and dirt and should be well greased, and if removed for any purpose care should be taken in replacing that the spring which is within the nut (the latter being in halves) is properly compressed before entering the screw. The spring fitted in the deflection nut to obviate backlash, may be found stronger than is necessary for its work, the result being stiffening and increased wear on the screw. The spring should require a weight of 5 to 7 lbs. to compress it to .9 in. The Armament Artificer will test the spring and shorten it if found necessary.

*Adjusting bush.*—Plate XI. To be kept clean and well oiled, and if removed for any purpose, steps should be taken to have the sight adjusted to the vertical plane of the gun.

*Yard scale ring.*—This should be kept clean and oiled, and if removed for any purpose, on replacing it should be set to the horizontal plane of the gun and sight.

*Clinometer sight.*—Should be kept oiled and free from grit and in perfect adjustment.

*Capsquares.*—To remove cradle capsquares for cleaning, &c., the carriage body must be traversed as far as it will go to the left to admit of the right capsquare key being removed, and to the right to remove the left key.

*To remove the outer spring case from cradle :—*

1. Dismount the gun.
2. Carefully remove the buffer, consisting of the cylinder, piston rod, inner and outer springs and inner spring case.
3. Remove the upper protectors (curved), fore sight, upper hand-wheel pinion spindle of the elevating gear and the indicator pinion of the range gear.

4. Unscrew the spring case (by means of a rope and a handspike, or other suitable appliance). Care must be taken when the first portion of the thread of the spring case is disengaged from the cradle, that the second (and third, with Mark I cases) portion of the thread is properly entered and not cross-threaded, also that the threads are clean and lubricated.

*To replace the outer spring case :—*

1. The converse of the above action takes place in re-assembling the spring case and buffer.

2. Before mounting the gun the "protector slide" on the front end of the cradle should be removed to prevent the leather portion of the protector forcing out the metal and breaking off the screws when sliding the gun home.

3. After the gun is mounted, replace the "protector slide."

*Replacement limits of running out springs.*—The normal free length of each running out spring is as follows :—

Inner	..	..	..	..	..	18.58 ins.
Outer	..	..	..	..	..	19.65 ins.

Any one spring, inner or outer, found with a permanent set of  $1\frac{1}{4}$  ins. or more below the normal free length of the spring, will be replaced.

#### LIMBER AND WAGON.

*Lids, wagon limber.*—In opening and closing the lids of this limber the centre lid must be opened first and closed last.

In order to prevent the wickerwork of the baskets from deterioration from wet (due to condensation) resulting possibly in damage to the ammunition, the lids of the limbers and wagons should be left open in dry weather daily to thoroughly dry the interior. Care is to be taken, however, that dust is excluded as far as practicable. Felt joints are to be kept in good order to exclude water from the interior of the boxes.

#### Amendments to Q.F., 13-pr., Handbook 1913.

Page 9.—Delete line 5 from bottom of page, and substitute the following under the heading of "Instructions for use of gauge."

Swing the breech screw and carrier into the loading position and remove the striker. Take out the main spring from the striker and reassemble the latter. Replace the striker (without main spring) in position in the breech mechanism, press in the "Catch, retaining, breech screw," and revolve the breech screw in the carrier until it is in the position it would be for firing if the breech were closed. Press the striker forward in the breech screw as far as it will go and apply the gauge to the front face of the breech screw.

If the protrusion of the firing pin is not between the limits of .09 in. to 0.11 in., as shown by the gauge, the firing pin will be exchanged.

### Amendments to Q.F., 18-pr., Handbook 1913.

Page 10.—Delete line 5 from top of page and substitute the following under the heading of "Instructions for using the gauge":—

Swing the breech screw and carrier into the loading position and remove the striker. Take out the main spring from the striker and reassemble the latter. Replace the striker (without main spring) in position in the breech mechanism, press in the "Catch, retaining, breech screw," and revolve the breech screw in the carrier until it is in the position it would be for firing if the breech were closed.

Press the striker forward in the breech screw as far as it will go and apply the gauge to the front face of the breech screw.

If the protrusion of the firing pin is not between the limits of .09 in. to .11 in., as shown by the gauge, the firing pin will be exchanged.

ORDNANCE, Q. F., 18 PR. MARKS I, I\* AND II.

SCALE =  $\frac{1}{12}$ .

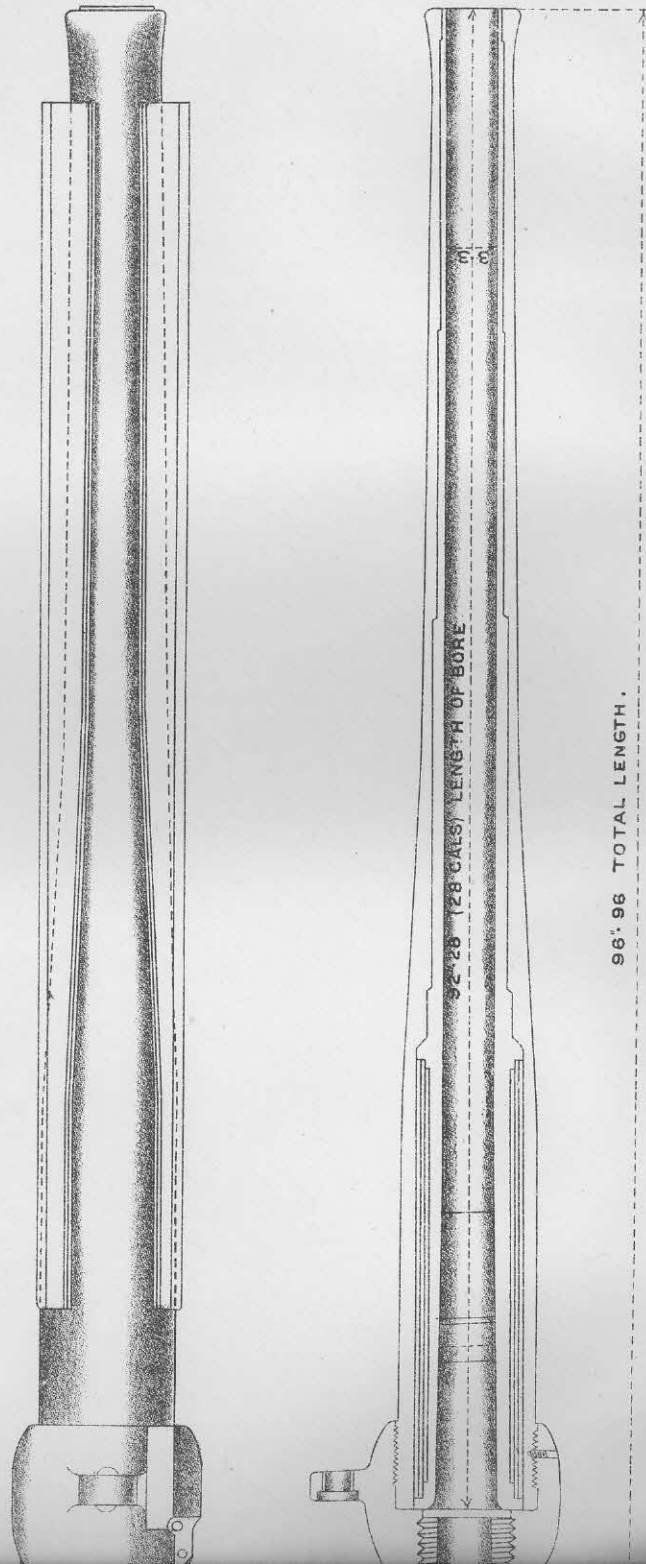

HANDBOOK

OF THE

18-PR. Q.F. GUN.

GUNS.

Material	... ..	Steel (wire construction).
Weight (with breech fittings)...	...	9 cwt.
Length, total	... ..	96.96 inches.
Bore,	calibre	... .. 3.3 inches.
	length (to face of breech screw)	... .. 92.62 inches.
Rifling,	system	... .. Polygroove, modified plain section.
	length	... .. 80.232 inches.
	twist	... .. Uniform, 1 turn in 30 calibres.
	grooves,	number
depth...		... .. .04 inch.
Firing mechanism	width...	... .. .384 inch.
	...	... .. Percussion.

GUN BODY, MARK I.

(Plate I.)

The gun is made of steel, and consists of the "A" tube, a series of layers of steel wire, jacket, and breech ring. The "A" tube extends from the rear end of the chamber to the muzzle. Over a portion of the "A" tube are wound successive layers of steel wire. The jacket is fitted over the exterior of the wire and "A" tube, and is secured longitudinally by corresponding shoulders and the breech ring, which is screwed over the jacket at the rear, and secured by a set screw. The breech ring is prepared for the reception of the breech mechanism, and is provided on the upper side with a lug for the attachment of the hydraulic buffer. Longitudinal projections on each side of the jacket form guides for the gun when in the cradle of the carriage.

GUN BODY, MARK I\*.

Mark I\* guns are Mark I guns repaired by the renewal of the "A" tube.

The repair consists in fitting into the old jacket under hydraulic pressure, a new "A" tube with new wire winding. The exterior of

the "A" tube with its wire is slightly tapered, and the interior of the jacket is bored to correspond.

#### GUN BODY, MARK II.

(Plate I.)

Mark II guns differ from Mark I as follows:—

The exterior of the "A" tube is slightly conical, the interior of the jacket being coned in a corresponding manner to admit of the guns being built up by means of hydraulic pressure instead of by shrinkage.

#### GUN BODIES, MARKS I, I\* AND II.

The chamber is slightly coned throughout its length, to facilitate the extraction of the cartridge.

A plane for clinometer is prepared on the upper surface of the breech ring.

An axis line is cut at the breech on the right side. Vertical and horizontal lines are also cut on the muzzle face and horizontal lines on the breech face.

#### BREECH MECHANISM.

(Plate II.)

The guns are fitted with "Single Motion Breech Mechanism." The mechanism is so arranged that by one pull on a lever the breech is unlocked and the screw and carrier are swung into the loading position. After loading, one thrust on the same lever inserts the breech screw into the breech opening and turns it into the locked position.

#### BREECH CLOSING MECHANISM.

The breech is closed by a steel screw tapering towards the rear. Segments of the screw thread are removed from opposite sides of the screw, and the breech opening of the gun being prepared in a corresponding manner, admits of the screw being locked in the gun by the fourth of a turn.

The screw is provided on the rear end with left hand screw threads which engage with corresponding screw threads in the inner face of the carrier.

The carrier for supporting the breech screw, when withdrawn from the gun, consists of a steel arm hinged to the right side of the gun at the breech. It is prepared on the inner face for the reception of the breech screw, and on the outer face with a recess for the striker guide block and two lugs for the hinge bolt of the breech mechanism lever. A steel catch with spiral spring is fitted to the interior of the carrier and serves to retain the breech screw in the open position. The catch is automatically released in closing the breech.

Hinged to the rear face of the carrier is a breech mechanism lever, provided with bevel teeth which engage with corresponding teeth on the rear face of the breech screw, so arranged that when the lever is pulled to the right, the first movement of the lever unlocks the breech screw, and on continuing the motion, the screw and carrier are swung into the loading position.

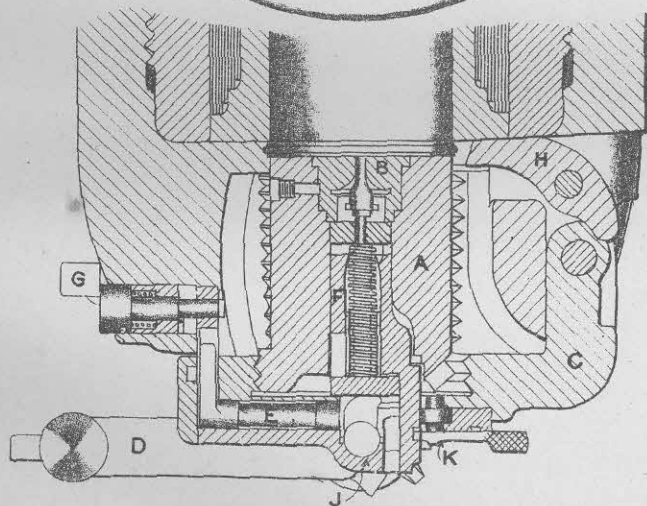
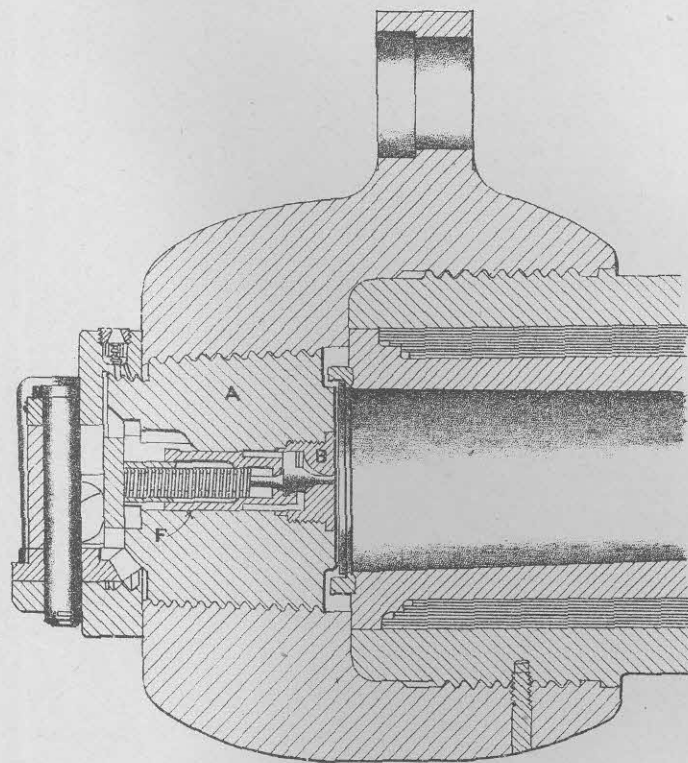
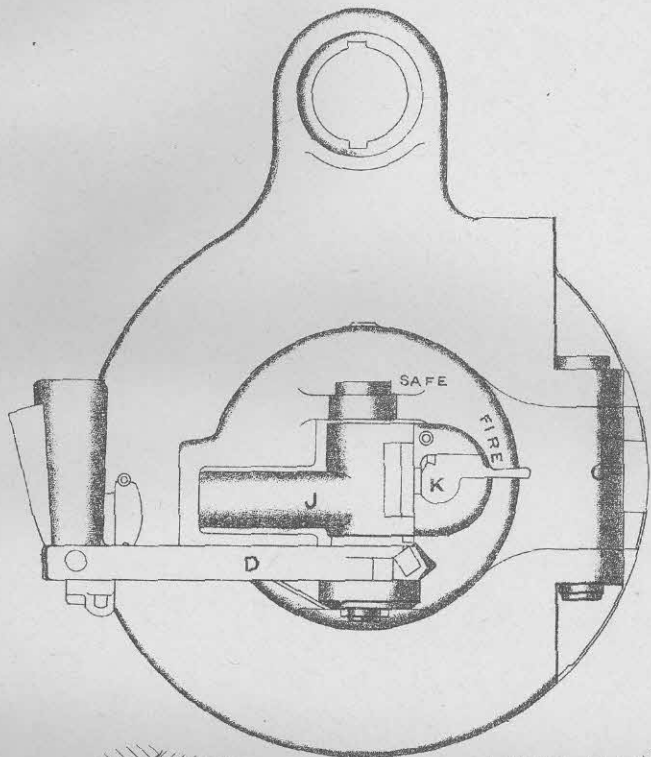

ORDNANCE, Q.F. 18 PR.

GENERAL ARRANGEMENT OF BREECH MECHANISM.

SCALE = 1/4.

- |                            |                         |
|----------------------------|-------------------------|
| A. BREECH SCREW.           | F. STRIKER.             |
| B. FIRING HOLE BUSH.       | G. TRIGGER.             |
| C. CARRIER.                | H. EXTRACTOR.           |
| D. BREECH MECHANISM LEVER. | J. STRIKER GUIDE BLOCK. |
| F. FIRING LEVER.           | K. SAFETY CATCH.        |

STRIKER.

SCALE  $\frac{1}{1}$

- A STRIKER.
- B FIRING PIN.
- C REBOUND BLOCK.
- D SECURING PIN.
- E MAIN SPRING.
- F GUIDE FOR SPRING.
- G TRIPPING PIECE.

- H. SPRING FOR TRIPPING PIECE.
- J. FIRING LEVER.

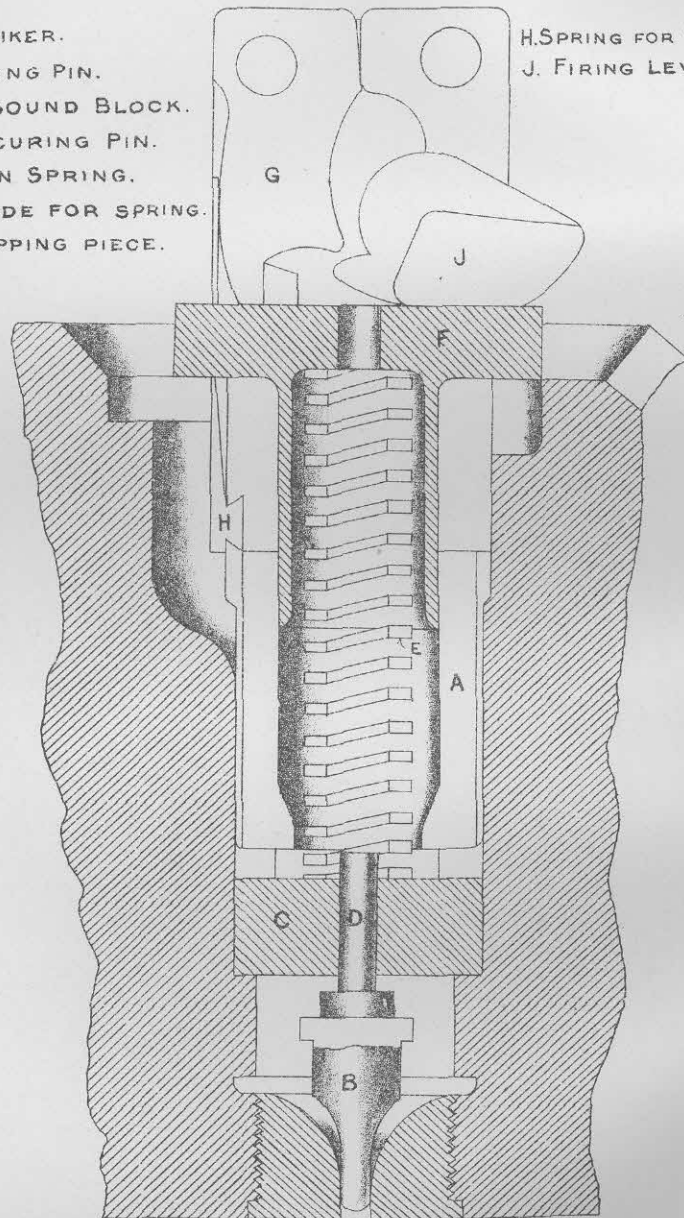

The breech mechanism lever is retained in the closed position by means of a catch with flat spring, pivoted in the lever, one end of which engages a recess in the lower lug on the rear face of the carrier.

FIRING MECHANISM.

(Plate III.)

The firing mechanism is for percussion firing, and is so arranged that the gun cannot be fired before the breech screw is locked and the breech mechanism lever home.

It consists of a striker with firing pin, rebound block and securing pin, main spring, guide for spring, and tripping piece with flat spring and fixing screw, fitted through the centre of the breech screw and retained in position by the striker guide block on the carrier. A steel firing lever in the interior of the striker guide block, serves to cock the striker and fire the gun, one end of the lever engaging with the tripping piece and guide for spring, and the other end with the trigger in the left side of the gun when the breech is closed.

The trigger is actuated by a direct pull on the firing gear of the carriage, thus partially revolving the firing lever, by means of which the striker is forced to the rear, and the guide for spring to the front, compressing the main spring until the projecting toe on the inner end of the firing lever slips past the front end of the tripping piece in the striker guide block, when the striker is free to go forward with momentum due to the energy stored up in the compressed main spring, and detonates the percussion primer of the cartridge.

The firing lever is returned to the firing position by means of the guide for spring.

The front end of the firing pin in the striker is withdrawn within the firing hole bush by means of a rebound block in the striker, which engages a recess in the breech screw for its reception.

A loop is provided on the lower part of the trigger for the attachment of a firing lanyard if required.

A safety catch, with flat spring, is fitted to the striker guide block for retaining the striker in the uncocked position, thus admitting of the gun being travelled with a cartridge in the bore.

*Note.*—The hook of the firing lanyard is of special pattern, and must be attached to the loop on the trigger as shown on Plate IV.

Should a jam occur after firing, care must be taken to see that the striker is flush with the rear end of the striker guide block before force is used to open the breech. In cases where the striker is not flush with the guide block, withdraw the keep pin and hinge bolt of the breech mechanism lever and remove the lever, guide block, firing lever, and striker from the gun. Replace the breech mechanism lever and hinge bolt, and swing the breech screw and carrier into the loading position. Replace the striker, firing lever, and guide block.

EXTRACTOR.

The extractor is of steel, and is hinged to the right side of the gun. On the inner end are two arms which clip the rim of the cartridge, the outer end forming a lug, by means of which the extractor is automatically actuated in opening the breech.

PIN, FIRING, DUMMY, AND SCREW, BREECH, DUMMY.

The above-mentioned fittings are provided for drill and instructional purposes, and are intended to prevent wear to the service mechanism and breech opening of gun.

The dummy firing pin differs from the service pin in not having the portion which projects through the firing hole bush.

The body of the dummy breech screw is of wood, having front and rear bronze plates, and a copper alloy ring with screw thread, which engages the screw threads in the breech opening of the gun. The rear plate is arranged to fit the carrier, and is provided with bevel teeth corresponding with those on the breech mechanism lever. The interior of the breech screw is recessed for the reception of the service striker with firing pin removed and dummy firing pin substituted. The interior of the front plate is fitted with an indiarubber pad to take the blow of the dummy firing pin when the trigger is pulled; this pad, when worn out, will not be replaced.

Dummy breech screws of latest manufacture have the outer face of the front bronze plate made similar in shape to the front end of the service breech screw, but slightly larger in diameter, so as to work the extractor in the gun. Such dummy breech screws are described as Mark II. Existing screws altered to conform to the Mark II pattern are known as Mark I\*.

In the case of Q.F. 18-pr. guns using Mark I dummy breech screws, if the drill cartridge case is not used for loading on account of grit, etc. getting on the breech screw, the extractor should be removed from the gun.

INSTRUCTIONS FOR REMOVING AND REPLACING BREECH FITTINGS.

TO REMOVE THE BREECH FITTINGS.

Before commencing to remove the fittings, the breech screw and carrier should be swung into the loading position.

*Breech Mechanism Lever, Guide Block, Firing Lever, Striker and Firing Pin.*

Remove the keep pin of the breech mechanism lever hinge bolt, and withdraw the hinge bolt, when the breech mechanism lever, guide block with firing lever, and striker can be removed. Slide the firing pin out of the striker.

*Breech Screw and Retaining Catch.*

Press in the catch retaining breech screw clear of the recess in the screw and unscrew the latter (to the right) from the carrier. Withdraw the retaining catch with spiral spring.

*Firing Hole Bushes, Marks I and II.*

(This will only be carried out by an Armament Artificer.)

Unscrew the bush from the interior of the breech screw by means of the special wrench. In the case of Mark II bushes, care must be taken to first remove the fixing screw for the bush in the breech screw.

*Carrier.*

Remove the keep pin of the carrier hinge bolt, and withdraw the hinge bolt and carrier.

*Extractor.*

Remove the keep pin of the extractor hinge bolt, and withdraw the hinge bolt and extractor.

*Trigger.*

Remove the keep pin and withdraw "Part I" trigger with bush, collar, and spring from the left side, and "Part II" trigger to the rear.

*Striker and Guide Block.*

When removing the striker from, or inserting it into, the guide block, the safety catch in the latter must always be in the firing position.

*Striker, Main Spring, &c.*

Press on the top of the spring guide so as to slightly compress the main spring, and at the same time tilt the upper end of the guide from the striker, and withdraw the guide and main spring. Slide the firing pin out of the groove in the front end of the striker. Remove the pin securing rebound block, and withdraw the latter.

*Safety Catch, Guide Block.*

Place the safety catch in the firing position, and force it out of its recess in the guide block towards the centre of the block, and withdraw it.

TO REPLACE THE BREECH FITTINGS.

The fittings are replaced in the reverse order.

When inserting the breech screw in the carrier, care must be taken, before commencing to screw in, to hold the breech screw "square" against the face of the carrier with one of the threaded portions of the screw uppermost, the stamping on the screw being to the rear. Two and one quarter turns of the breech screw are required in screwing in, the retaining catch being pressed in clear of the recess in the screw during this operation.

When inserting the trigger, first correctly assemble the spring with the projecting ends in the holes for their reception in the "Part I" trigger and bush, then insert the collar on the trigger with the recessed portion innermost, and twist the bush on the trigger until the projection on it engages with the recess in the collar. Insert "Part I" trigger with bush, collar, and spring into the left side of the gun, and engage with "Part II" trigger inserted from the rear. Insert keep pin.

SEPARATE DEMANDABLE STORES.

DRIFT, No. 12.

The drift is of steel and is for use in removing keep pins from the mechanism.

## GAUGE, STRIKER PROTRUSION, No. 1.

The gauge is of steel plate, and is for use in gauging the protrusion of firing pins or needles of strikers of Q.F. 6-in. to 12-pr. guns.

## INSTRUCTIONS FOR USE OF GAUGE.

See "Regulations for Magazines and Care of War Matériel."

## RIMER, BREECH SCREW, Q.F. 13 AND 18 PR.

The rimer is of steel, and consists of a cutter with holder, sleeve and guide block. It is for use in removing burrs from the striker recess in the breech screw.

## INSTRUCTIONS FOR USE OF RIMER.

See "Regulations for Magazines and Care of War Matériel."

## WRENCH, BREECH MECHANISM, No. 77.

The wrench is of steel, and is for use in removing or inserting the firing hole bush in the breech screw.

## SIDE ARMS, &amp;c.

*Cleaner, piassaba, No. 7.*—The cleaner consists of a piassaba brush fixed on the middle portion of a lanyard. A lead ball is attached by white line to one end of the lanyard so as to carry it through the bore of the gun.

*Cleaner, wool, No. 1.*—The wool cleaner is generally similar to the piassaba cleaner described above, from which it differs principally in having a wool sponge fixed in the middle portion of the lanyard instead of a brush.

*Cover, breech.*—The cover is made of waterproof canvas and formed to protect the breech mechanism of the gun, and the rocking bar sight; it is secured in position by lacing loops and quick release straps.

*Cover, muzzle.*—The cover is made of khaki-coloured waterproof canvas shaped to suit the muzzle of the gun; it is provided with a leather strap to secure it in position.

*Lanyard, firing, No. 15.*—The firing lanyard is made of tarred white line with steel hook on one end shaped to suit the trigger of Q.F. 18 and 13 pr. guns. A wood toggle is attached to the other end of the lanyard (see Plate IV).

## CARE AND PRESERVATION OF GUN AND FITTINGS.

See also "Regulations for Magazines and Care of War Matériel."

The breech fittings, and also the guides on the jacket by means of which the gun slides in the cradle of the carriage, should be kept clean and oiled or greased, and maintained in good working order; all working surfaces must be well lubricated, the fittings being taken off sometimes for this purpose, especially after firing.

Lubricating holes are prepared in the upper side of the carrier to admit of the rear end of the breech screw in the carrier being oiled.

LANYARD, FIRING, No 15 MARK I.

SCALE = 1/2.

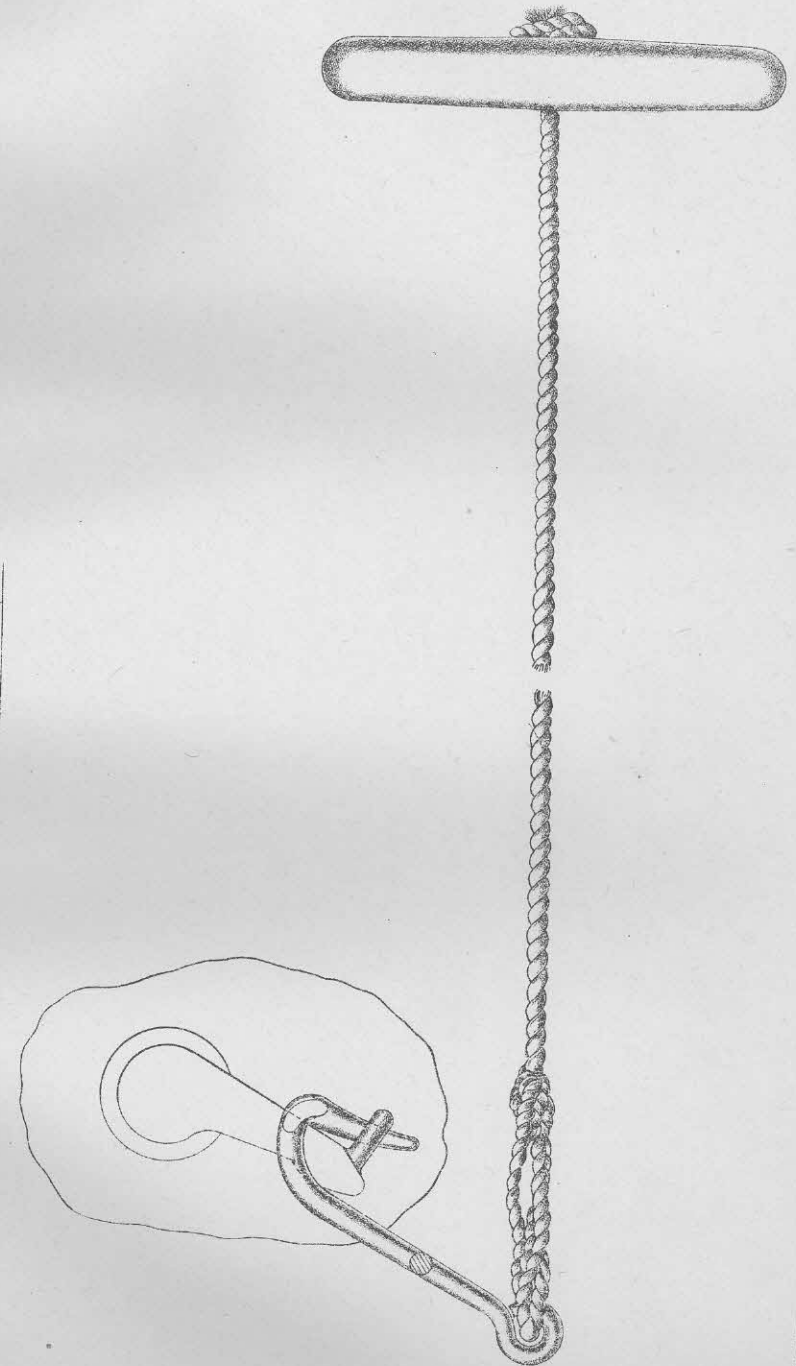



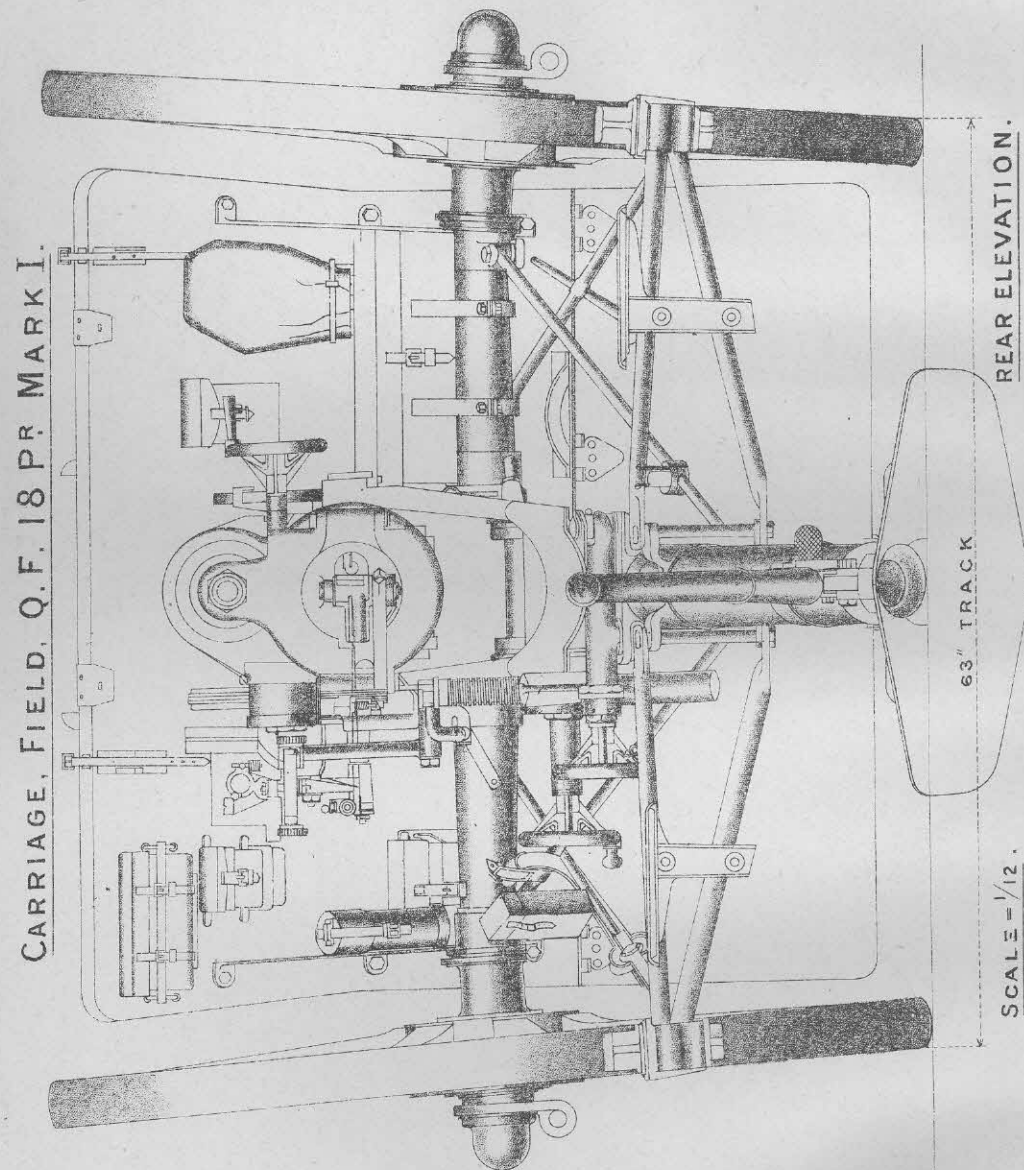

The holes are closed against the ingress of dust by means of a brass plunger and spiral spring which must be pressed down by the spout of the oil can when lubricating.

The breech should be kept covered up, when possible, to prevent dust and grit from getting into the interstices of the breech fittings, which might impede their easy working. A waterproof canvas cover is provided for the purpose.

A gauge, testing clinometer plane and axis of bore is provided for use of Inspecting Officers.

For description and use of gauge, see "Regulations for Army Ordnance Services, Part II."

A "gauge, plug, bore, low limit," for provisional condemnation is provided for use of Inspecting Officers, to save time and to avoid unnecessary measurements.

The gauge consists of a cast-iron cylinder having a handle formed at one end to facilitate insertion into the bore. A hole is made through the handle for the attachment of a line for pulling the gauge through the bore.

#### CARRIAGE, LIMBERS, WAGONS, &c.

Carriage, field, Q.F., 18-pr., Mark I.

(Plates V and VI.)

The carriage is constructed to allow of 16 degrees elevation and 5 degrees depression being given to the gun, which recoils axially in a cradle, the latter being fitted with a hydraulic buffer to limit the recoil to about 41 inches and running out springs to return the gun to the firing position. The carriage is also constructed so that the elevation of the gun can be altered without interfering with the line of sight. It is provided with a seat on each side of the trail for two of the gun detachment, and with a shield for the protection of the numbers serving the gun.

The carriage is fitted to carry various stores, see list of stores, p. 39, and packing diagram, p. 45.

The principal parts of the carriage are:—

Trail.	Traversing gear.
Carriage body.	Firing gear.
Cradle.	Brake gear.
Hydraulic buffer.	Shield.
Running out springs.	Axletree and wheels.
Elevating gear.	Sights.
Range gear.	

#### TRAIL.

The trail is tubular, and is secured to the underside of the axletree by a bracket, which also forms a pivot for the carriage body. The rear end is fitted with a spade, lifting handles, trail eye, and a traversing lever, which latter can be folded down and held by a spring clip when not in use. The trail is further supported by a tensile stay on each side, one end of which is attached to the axletree by a bracket.

## CARRIAGE BODY.

The body, which is attached to the trail, consists principally of two triangular-shaped frames connected by transoms, and provided with bearings, through which the axletree passes and by which it is pivoted for traversing.

## CRADLE.

The cradle is of bronze, with steel trunnions to pivot it to the carriage body, the left trunnion being prolonged and threaded for the reception of a stud for supporting the rocking bar sight; it has an opening in the lower portion for the gun and in the upper portion for the spring case. Longitudinal recesses are cut in the inner surface of the lower portion for the reception of the guides on the jacket of the gun. A steel guard is fitted to the left side to protect the gun layer, and a notch and point are formed above the spring case for rough laying.

## CLAMPING GEAR.

(Plates VIII and X.)

The gear is provided to clamp the cradle to the carriage body in the travelling position. A spindle with clutches and handle is fixed to the carriage body, so that when the rear of the cradle is depressed to its full extent, in elevating the gun, the clutches may be made to engage with semicircular shaped lugs formed on the underside of the cradle, and rigidly fix the cradle to the carriage. A stop is fitted to the carriage body to limit the travel of the handle of the clutch spindle in the clamped position. This gear also determines the point of maximum elevation. In the event of the clamping gear becoming jammed and difficult to release, it can be overcome by easing the lower elevating wheel by hand before unclamping.

## HYDRAULIC BUFFER AND RUNNING OUT SPRINGS.

(Plate VII.)

The hydraulic buffer, which is contained in the spring case in the upper portion of the cradle, consists of a cylinder, piston, piston rod, controlling plunger, and stuffing box with gland. The cylinder is closed at the rear by the controlling plunger and at the front by the stuffing box and gland, which are locked in the required position by a spring stud. The gun is attached to the cylinder and secured by two nuts. A number of longitudinal grooves of varying depth are formed on the inner surface of the cylinder, so that the space for the flow of the liquid between the piston and the cylinder varies during recoil; by this means an approximately constant pressure is maintained in the buffer throughout the stroke. The front end of the piston rod is fixed to the front of the spring case. The rear end is bored for the reception of the controlling plunger, which, by displacing the liquid inside the piston rod, brings the gun gently to rest when returning to the firing position.

A filling hole, closed by a plug with chain, is provided at the rear end of the cylinder.

To face page 12.

- A. CAP, OUTER SPRING CASE.
- B. CASE, SPRING, INNER.
- C. CYLINDER.
- D. GLAND.
- E. NUT, SECURING, CYLINDER, OUTER.
- F. " " " " INNER.
- G. NUT, PISTON ROD.
- H. PIN, KEEP STUD, RETAINING, STUFFING BOX.

# CARRIAGE, FIELD, Q.M.

SECTIONAL ELEVATION OF HYDRAULIC B

SCALE = 1/4

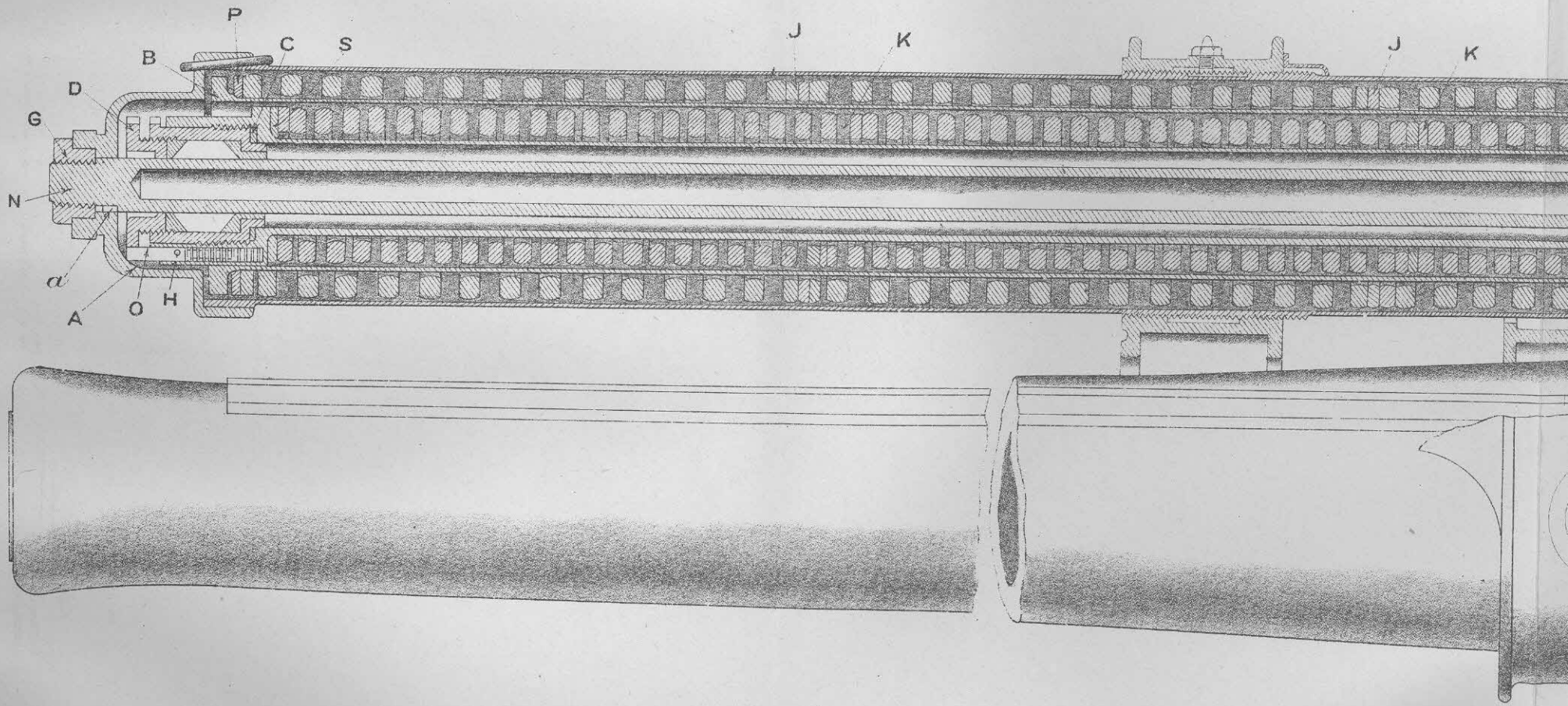





when in action; for travelling, it is secured to the trail by a pawl, with a releasing lever and locking pin. Two straight edges on the top of the shield indicate the approximate field covered by the traversing gear, as seen by the number standing at the traversing lever.

Leather cases and fittings are provided for carrying on the shield and axletree a dial sight, field clinometer, sight clinometer, spare parts, fuze keys, shovel, aiming posts, breech and muzzle covers, oil can, fuze indicator, tool case and telescope. An advance loop is fitted to the centre of the shield.

The lifting jack will be applied from the front of the carriage under the outer hinges of the shield.

#### AXLETREE AND WHEELS.

The axletree (2nd class, "C," No. 206) is a tubular steel forging; it is connected to the trail by three brackets, the outer brackets being recessed on the outer faces for the reception of an L-shaped leather ring, which is secured by a steel plate. The L-leather envelops the inner end of pipe box, and prevents the ingress of dirt, dust, &c. The outer end of each arm is fitted for a linch pin and an adjusting collar, which has a number of recesses (through which the linch pin passes) cut in one face; the recesses are of varying depths, from .2 inch to .5 inch, increasing by .05 inch, so that any reduction in the length of the pipe box, due to wear, may be adjusted.

The wheels are 2nd class, "C," No. 45, 4 ft. 8 in. diameter, with steel nave, removable pipe box, and a 3-inch steel tire with rounded edges. The nave consists of two flanges of corrugated steel, which are connected by bolts. The inner flange is fitted with a steel ring to strengthen it, and the outer flange with a centring ring. The pipe box passes through the centre of the flanges, and is secured by a nut, which is prevented from working loose by a flat spring which is fixed to the pipe box and engages with one of a number of indents on the rim of the nut. A dust cap is screwed on the outer end of the pipe box; it encloses the adjusting collar, linch pin, and the end of the axletree arm. The inner face of the cap is recessed for the reception of a corresponding projecting ring on the nut, the cap being secured to the nut by a split keep pin. The pipe box is provided with a lubricating hole, which is closed with a  $\frac{1}{2}$ -inch screw.

The drag washer is free to revolve round the nut, and is secured by the dust cap.

On an emergency, a 2nd class, "C," No. 200 wheel may be used to replace a No. 45 wheel, in which case the adjusting collar and linch pin for capped wheels may be used, the linch pin being secured by a piece of wire or a leather lace. In place of the adjusting collar and linch pin, the ordinary 2nd class drag washer and linch pin can, if desired, be used.

When using No. 200 wheels which have not had the inner flange reduced in diameter, the dust excluder (leather with keep plate) must be first removed.

#### SIGHTING.

The carriage is fitted on the left side with a rocking bar sight with sight clinometer, and No. 4 sighting telescope. It is provided with a No. 1 dial sight or No. 7 dial sight and No. 2 carrier.

## ROCKING BAR SIGHT.

*(Plate XI.)*

The rocking bar sight consists principally of a rocking bar and a sight bar. The rocking bar is pivoted horizontally at the front end to an arm on the left trunnion of the cradle. A bracket is riveted to the underside at the rear end to carry a sight clinometer. An open square socket is formed in the bracket for the reception of a similar shaped projection on the arc bracket of the range gear, by which the reciprocating motion of the elevating screw is conveyed to the bar. The rear end is provided with a crosshead with a traversing screw with milled heads, and a nut which enables 5 degrees of deflection right or left to be given to the sight bar. Degrees of deflection are marked on a scale plate, and minutes in multiples of 5 on a ring fixed to each of the milled heads of the traversing screw.

The sight bar is pivoted vertically about the centre to a socket with an adjustable bush in the rocking bar. The rear end of the bar is fixed to the traversing nut. The nut on the deflection screw is in two parts having a spring inserted to keep the halves apart; the object of this arrangement is to take up backlash in the deflection gear due to the wear of the screw. Two holders with caps secured by spring clamps are fitted to the bar to carry a "Telescope, sighting, No. 4." The rear holder is fitted with a notched leaf hind sight, and the front end of the bar with an adjustable acorn-pointed fore sight. A cap is provided for the protection of the sight. The rocking bar sight is removable, being attached to the trunnion arm by a securing key with a chain.

The permanent angle of deflection for drift is given by the axis of the trunnion cradle being inclined at an angle of  $1\frac{1}{2}$  degree, the left trunnion being the lower, so that as elevation is given, the gun muzzle moves to the left the necessary amount to correct for drift.

## SIGHT CLINOMETER.

*(Plate XI.)*

The sight clinometer is used to give the "angle of sight," and admits of 20 degrees elevation or 20 degrees depression. It is constructed so that it may readily be attached to the rocking bar sight. It consists principally of a cradle with a worm spindle, and a toothed arc with a spirit level. The cradle is fitted on the underside with spring clips for fixing it to the rocking bar, and with radial grooves on the top, in which the arc slides; the worm spindle passes through the centre of the cradle, and is supported at each end by movable bearings, one of which is pivoted to the cradle, and the other free to slide in grooves for a limited distance, so that the worm on the spindle may be readily disengaged from the teeth in the arc when necessary for quick adjustment. The worm is kept up to its work by a flat spring with a bearing surface on its underside, and each end of the spindle is fitted with a micrometer collar marked to read minutes in multiples of 5. The arc consists of a toothed segment with a spirit level above; it slides in the grooves on the cradle, and the teeth engage with the worm on the spindle; an adjustable pointer is fitted below the level for reading the degrees of elevation and depression engraved on the cradle.

CARRIAGE, FIELD, Q.F. 18 PR MARK I.

GENERAL ARRANGEMENT OF ROCKING BAR SIGHT WITH SIGHT CLINOMETER IN POSITION

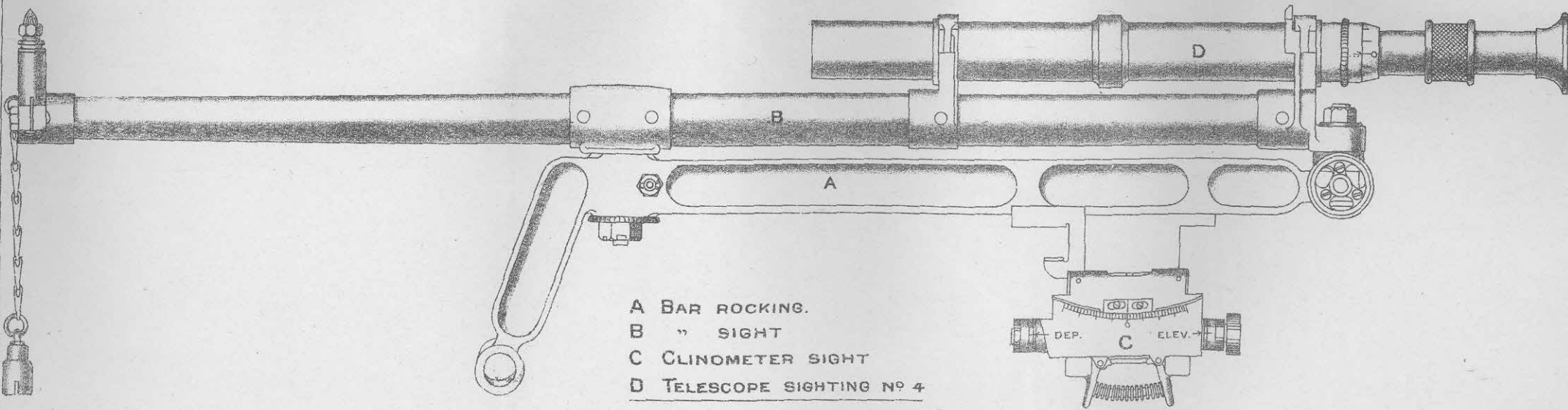
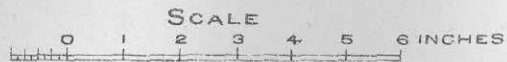

- A BAR ROCKING.
- B " SIGHT
- C CLINOMETER SIGHT
- D TELESCOPE SIGHTING NO 4



## TELESCOPE SIGHTING, NO. 4.

*Particulars.*

Magnification	...	...	...	5½ diameters.
Field of view	...	...	...	5½ degrees.
Length over all	...	...	...	17.25 inches.
Weight	...	...	...	2 lb. 12 oz.

*Mark I.*—The telescope is of the ordinary erecting type, with an object glass and terrestrial eyepiece.

The body is fitted with two gunmetal collars, which accurately fit the bearings on the sight bar; the rear collar has a small projecting pin, which prevents the telescope from turning in the bearings.

The eyepiece is fitted with a metal eye guard, and a diaphragm carrying a needle-shaped pointer is fixed at the focal length of the object glass. The eyepiece also carries an engraved ring numbered 0 to 7, which in conjunction with an arrow on the body, registers the turning movement of the eyepiece, 4 being the position for normal vision, so that individual layers may set their focus to the figure previously determined.

The object glass is fixed in the correct position for infinite focus, or, in other words, for all objects over 400 yards distant. It is protected by a ray shade.

Two caps, connected by a sling, are provided to protect each end of the telescope; the sling is attached to the body of the telescope by a small strap with buckles.

*Mark II.*—Mark II differs from Mark I in the diaphragm which carries the pointer being made adjustable, so that collimation may be carried out by moving the diaphragm, instead of by rotating the object glass in eccentric rings.

*Mark III.*—Mark III is generally similar to the Mark II, except that the dimensions differ slightly. Several parts are made interchangeable.

*To focus the Telescope.*

The telescope is issued with the object glass fixed at its point of infinite focus, and is then suitable for all distances over 400 yards; it therefore only remains to focus the pointer with the eyepiece. To do this, place the telescope in its bearings, fasten down the clips and direct the telescope on a well-defined object, preferably about 1,000 yards or more distant.

Screw the eyepiece in or out until the pointer stands out clearly; the object will then stand out clearly at the same time.

*Care of Telescope.*

See "Regulations for Magazine and Care of War Matériel."

## DIAL SIGHT, NO. 1, MARKS I\* AND II.

The dial sight consists of a circular carrying plate with degree scale ring, a crosshead and pin, and a sight plate with pointer. The carrying plate is hinged at the centre to the crosshead, and the crosshead

is hinged transversely to the crosshead pin. This arrangement admits of an adjustment right and left to compensate for any difference that may occur in level of the wheels, and for elevation or depression being given to the plate and sight. The degree scale ring is fixed to the periphery of the carrying plate by screws; it is marked in degrees, 180 on each side of zero, the required angle being read by means of a pointer fixed to the rear end of the sight plate. Should it be found by examination that when the sight line and axis of the gun are parallel, 0 degrees is *not* indicated, the pointer is so formed as to admit of the required adjustment being made. The sight plate is pivoted to the centre of the carrying plate and jointed near its centre; the joint pin is provided with a thumb nut for clamping the plate in the extended or folded position; the plate is fitted with an acorn-pointed fore sight at the front end, and notched to form a hind sight at the rear end. A clamping screw is provided to fix the sight plate at the required angle. The sight is fixed to the bracket by the crosshead pin, which fits into a corresponding socket, and is secured by a keep pin.

SIGHT, DIAL, No. 7 AND CARRIER, No. 7 DIAL SIGHT,  
No. 2.

(Plate XII.)

The No. 7 dial sight is provided for indirect laying. Whilst the eyepiece is fixed, the top portion can be revolved in any direction and set to any angle that may be ordered. This angle will usually be that between the lines to the target and to an aiming point. The top of the sight is at a higher level than the layer's eye, so that an aiming point in any direction can be seen, and the layer can always lay the gun from his position behind the shield.

There is an arrangement at the top of the sight by means of which the line of sight through the top prism can be elevated or depressed. The necessary magnification is given by an object glass and eyepiece.

When using the sight whole degrees must be put on to the main scale and minutes on the micrometer head of the deflection or lower scale. After making use of the quick release for setting the main scale, the micrometer head must be turned through several degrees (to ensure that the worm and rack are properly engaged) before making the final adjustment.

The No. 2 carrier consists of a steel bar which can be clamped into a fitting on the cradle. The upper portion is shaped to take the dial sight. It is also fitted with an arrangement for giving deflection up to 10 degrees right or left. This consists of an upper and lower bracket. The upper bracket is connected to the dial sight by means of four screws and a feather; fitted through it is a worm with a minute micrometer head at each end, readers for which are fitted on the bracket. Along one face is fixed the deflection degree scale. The lower bracket has worm teeth cut on it into which the worm gears. There is also a reader for the deflection degree scale attached to it. Right deflection is indicated by white graduations on a black background.

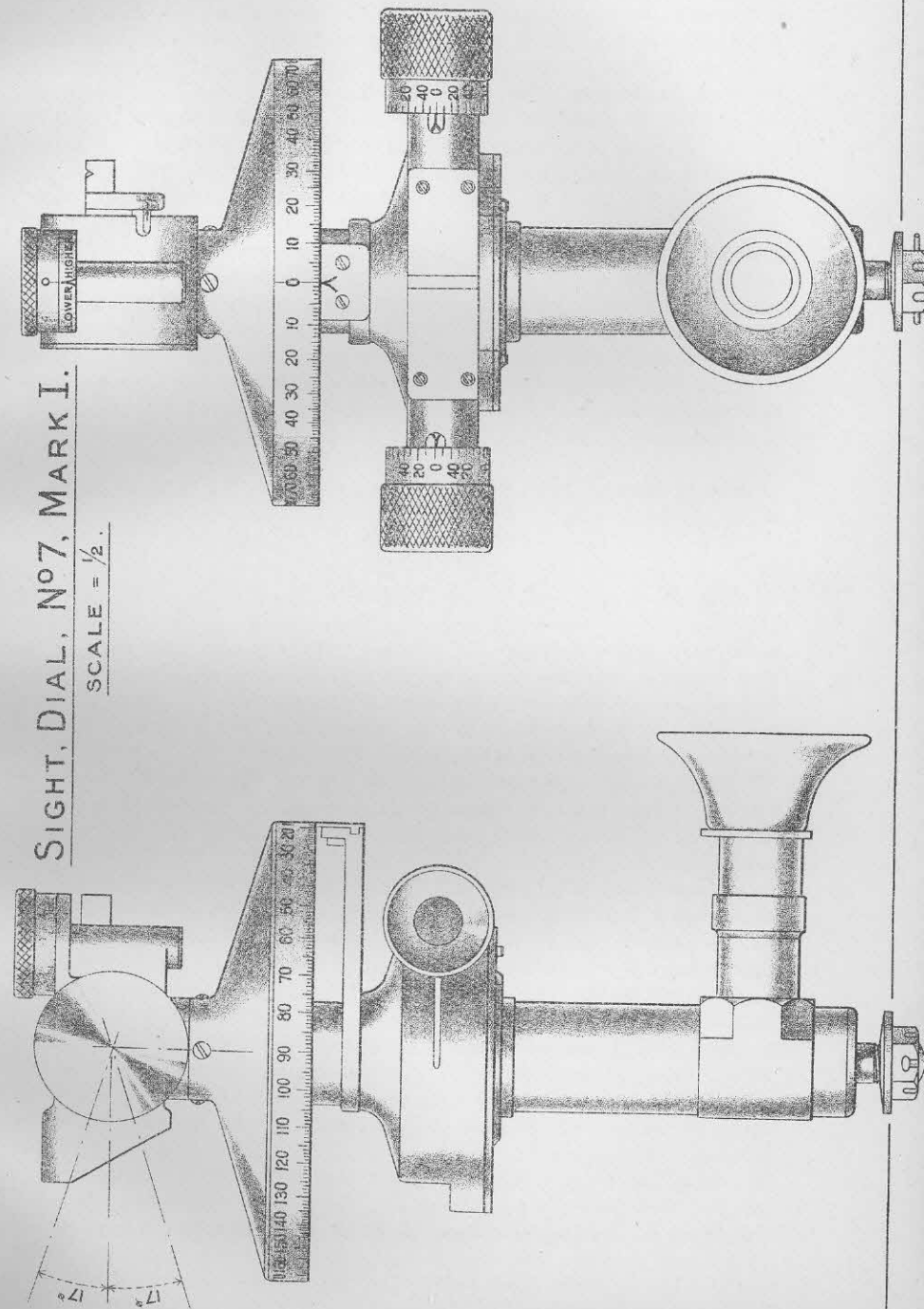

SIGHT, DIAL, No 7, MARK I.

SCALE = 3/4.

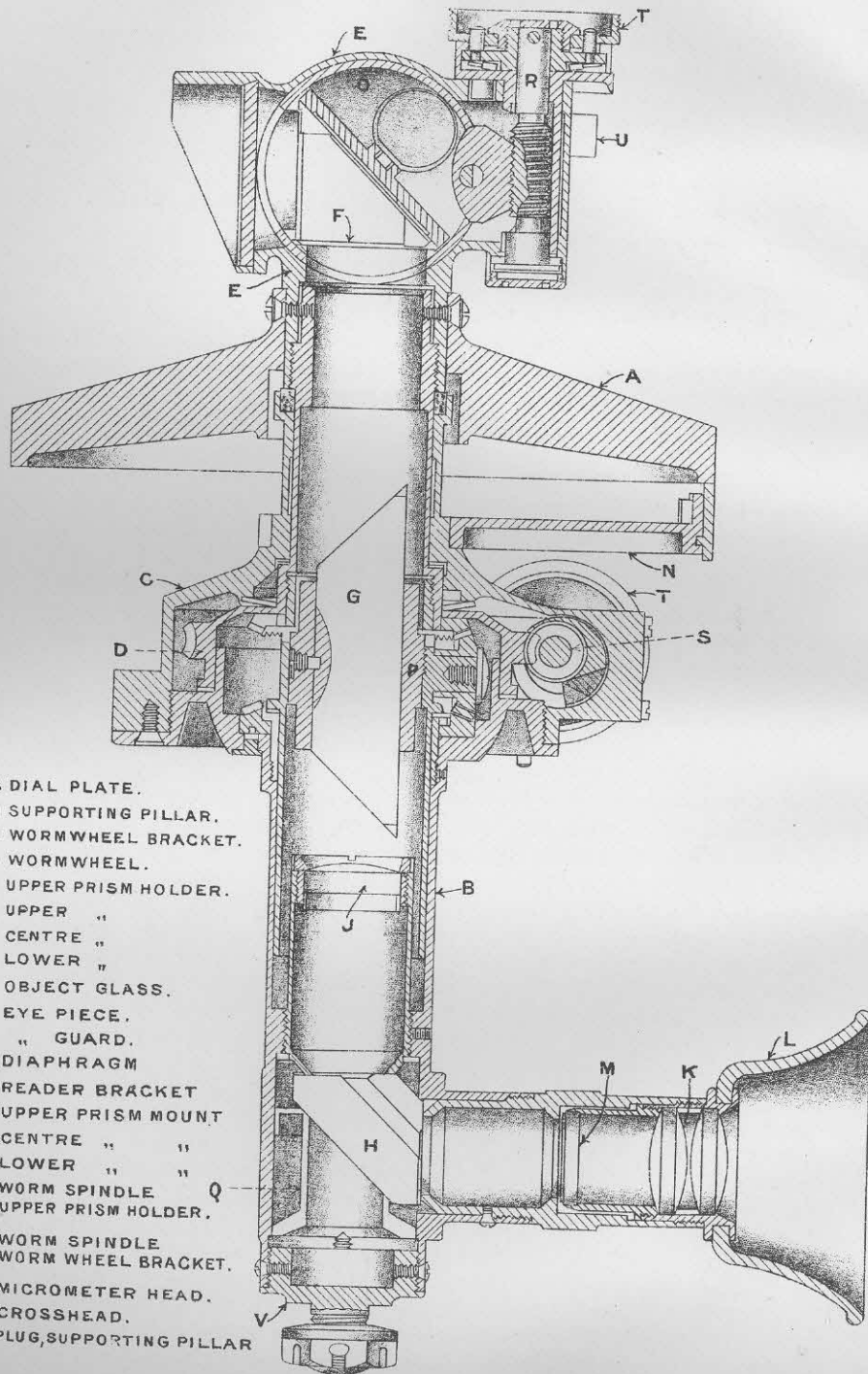

- A DIAL PLATE.
- B SUPPORTING PILLAR.
- C WORMWHEEL BRACKET.
- D WORMWHEEL.
- E UPPER PRISM HOLDER.
- F UPPER "
- G CENTRE "
- H LOWER "
- J OBJECT GLASS.
- K EYE PIECE.
- L " GUARD.
- M DIAPHRAGM
- N READER BRACKET
- O UPPER PRISM MOUNT
- P CENTRE "
- Q LOWER " "
- R WORM SPINDLE
- S WORM SPINDLE WORM WHEEL BRACKET.
- T MICROMETER HEAD.
- U CROSSHEAD.
- V PLUG, SUPPORTING PILLAR

SIGHT, DIAL, No. 7.

(Plate XIII.)

Mark I.—The principal particulars of the sight are as follows:—

Magnification ... ..	4 diameters.
Field of View ... ..	10 degrees.
Horizontal rotation of reflecting prism... ..	360 degrees.

The optical combination is of an erecting type, comprising an object glass and eyepiece with erecting and reflecting prisms.

The dial sight consists principally of supporting pillar, upper, centre and lower prisms, worm wheel bracket, worm wheel, dial plate, and upper prism holder.

The supporting pillar is tubular, L-shaped, and is arranged to fit the No. 2 carrier on the carriage. The horizontal portion of the pillar is furnished with an eyepiece and a glass diaphragm having cross lines. A window is provided to admit light to the cross lines, and a dermatine eyeguard to keep out the extraneous light from the gun layer's eye and to protect him when firing. The upper end of the pillar is prepared with a flange for the reception of the worm wheel and worm wheel bracket.

A steel plug is screwed into the lower end of the supporting pillar, and is provided with a stud with nut and keep pin, the spring washer in the No. 2 carrier pressing against the top of the nut.

In order to keep the image always erect, the centre prism is made to revolve at half the speed of the top prism. This is effected by internal bevel gearing.

To the top of the pillar is attached a worm wheel bracket. A worm spindle in this bracket engages with the worm wheel. At either end of this worm spindle is a drum graduated in divisions of ten minutes; each revolution of the drum represents five degrees. The drum on the right is marked in white figures on black; that on the left in black figures on brass. By moving these drums, minutes of angle can be added to the degrees shown on the scale of the dial plate. The worm spindle is mounted on an eccentric bearing fitted with an actuating collar and thumb piece. When the thumb piece is moved upwards the worm is disengaged from the worm wheel, and the dial plate can be swung round. Fitted above the worm wheel bracket is a reader for the dial plate.

Attached to the worm wheel are the dial plate and a holder for the upper prism. The dial plate is graduated to read from 0 to 180 degrees "Right" and "Left." The markings for "Right" are white on a black ground; those for "Left" black on a brass ground. The upper prism holder is fitted with a window and rainshade. A crosshead with notch and foresight for rough laying is pivoted to the holder. The prism and crosshead admit of vertical adjustment to 15 degrees elevation and depression by means of a worm spindle with a micrometer head. The micrometer head has a graduated drum engraved in divisions of 10 minutes. Each revolution of the worm spindle indicates 5 degrees elevation or depression on the crosshead. Underneath the crosshead is a scale showing graduations of 5 degrees; this scale is read by means of an arrow on the holder. Indicating arrows and the words "Higher" and "Lower" on the worm spindle

bearing, denote the direction in which the micrometer head should be turned for raising or depressing the line of sight, and act as a reader.

*Mark II.*—Dial sights differ from Mark I, described above, in the following particulars:—

The vertical scale graduations on the upper prism holder crosshead and micrometer head, except the zero and index marks, are omitted.

The worm wheel and worm spindle bearings are of manganese bronze or other non-corrodible metal instead of steel.

All springs and spring washers are nickel-plated.

A waterproof cover and holder to hold the No. 7 dial sight and No. 2 carrier is provided for carriage on the inside of the shield.

#### CARE AND PRESERVATION OF "SIGHT, DIAL, NO. 7" AND "CARRIER NO. 7 DIAL SIGHT, NO. 2."

The dial sight when issued from Woolwich is in correct adjustment, watertight, and with all the cells and joints secured with fixing screws.

It is very unlikely that the interior will be required to be cleaned, and the dial sight must on no account be taken to pieces.

The body of the dial sight must be cleaned with a clean soft cloth and a little oil, which must be rubbed off afterwards, care being taken that the glass is not touched.

The exterior of eyelens and window should be cleaned with chamois leather, specially kept for the purpose, and only by a competent person. Great care must be taken that no oil or grease is allowed to touch the glasses. Fingers when apparently clean and dry may leave marks on the lens which will impair the definition of the telescope.

Owing to the construction of the carrier the deflection arrangements should be occasionally tested for backlash by laying on a well-defined object and traversing the sight from right and left alternately by means of the deflection screw until the vertical crossline is aligned. If the deflection scale does not read the same in both instances, the difference of reading indicates the backlash.

Backlash may be due to the small coned portion of the carrier which is removed when inserting the sight in its carrier having become strained or not fitting properly.

To correct this, the removable portion of the coned surface of the carrier may perhaps be made to fit more perfectly by manipulating its fixing screws. If this fails, the coned surface of the removable portion should be slightly reduced with fine emery paper or a dead smooth file.

The No. 7 dial sight and No. 2 carrier will eventually supersede the No. 1 dial sight with Q.F. 18-pr. guns.

#### INSTRUCTIONS FOR TESTING AND ADJUSTING THE SIGHTS.

*Any adjustments required to optical instruments must be carried out by an Armament Artificer.*

#### TELESCOPE.

*Mark I Telescope.*—There is no internal adjustment provided for the Mark I telescope (except during manufacture); it is therefore less likely to get out of adjustment, and there are no small internal

## TARGET FOR TESTING SIGHTING GEAR.

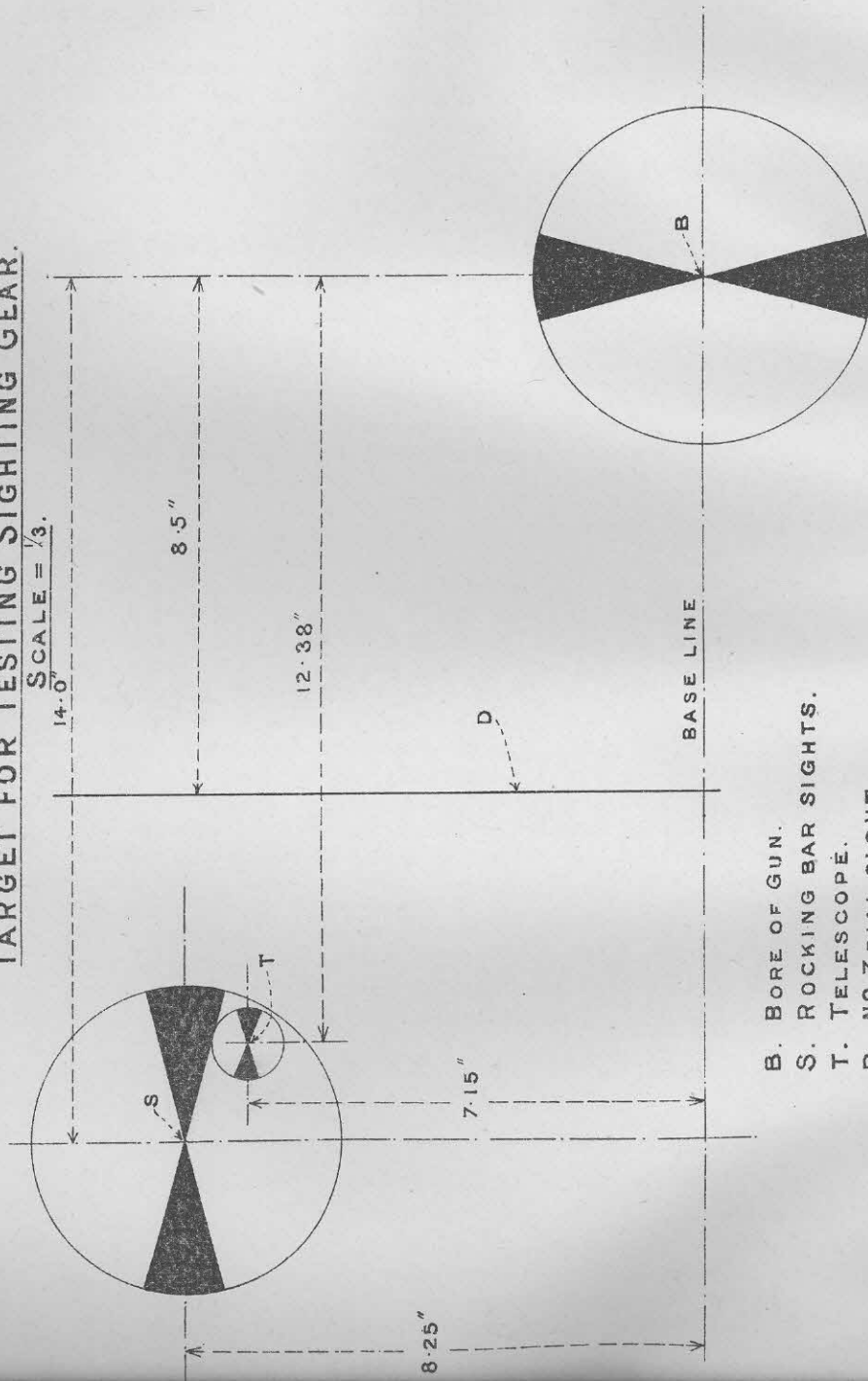

B. BORE OF GUN.

S. ROCKING BAR SIGHTS.

T. TELESCOPE.

D. NO 7 DIAL SIGHT.

screws to be manipulated. To obviate any small error left in the telescope during manufacture, the rear collar is provided with a pin to prevent the telescope being turned round in its bearings, and the small error is taken up by adjusting the fore sight.

### MARKS II AND III TELESCOPE. COLLIMATION.

*Test.*—Place the telescope in its bearings. Lay the pointer on some well-defined object. Release the hinged caps. Remove telescope and replace it, but with its pin uppermost. The tip of the pointer should remain on exactly the same point.

*Adjustment.*—If, when the telescope has been turned, the tip of the pointer appears to have moved *above* the point layed on, unscrew the capstan-headed screw beneath the telescope (having previously unscrewed the metal cap covering the capstan-headed screws) and screw up the one above the telescope until the pointer is brought half-way towards the point layed on, then by depressing the sight, move the pointer exactly on to the point layed on. Repeat the process until the pointer moves neither above nor below the point layed on.

If the pointer appears to have moved *below* the point layed on, reverse the above procedure.

Should the pointer move to either side of the object when the telescope is reversed it may be corrected in a similar manner.

See that all the capstan-headed screws are home, and replace the metal protecting cap.

### ALIGNMENT TESTS.

Before any of the following operations are carried out, the carriage should be placed on a firm platform, or on hard level ground, and manipulated until the gun is level transversely. If these arrangements cannot be conveniently made, the base line of the target (*Plate XIV*), if used, must be set parallel to the slope of the wheels.

(1) *To ascertain if the line of sight of the open sights is parallel to the axis of the telescope.*

Select a clearly defined object, at least one mile away, to lay on. The telescope and open sights should agree. If not, correct as detailed below.

If a clearly defined object is not available, construct a target with three circles on it—B, T, and S (*See Plate XIV*)—each circle divided into black and white sectors, the centres of the circles being the points to lay on. Set the targets up at a distance of about 50 yards from the gun. Lay the telescope by means of the elevating and traversing handwheels on the left side of the trail on the point "T." The open sights should now be on point "S." If not, correct as follows:—

Loosen the fixing screw below the fore sight with the spanner provided for the purpose and screw the acorn of the sight up or down until the line of sight is on "S." Then tighten up the fixing screw. There is no adjustment for transverse error, and should any error exist the telescope should be taken as correct. This error is not important, and is not likely to be large.

(2) *To ascertain whether vertical planes passing through the axis of the telescope and the axis of the gun are parallel to one another.*

Place the "Bush, testing sight, with cross wires" in the muzzle and remove the "Lever, breech mechanism." Set the sights at zero for elevation and deflection and lay through the bore on the distant point, or, alternatively, point "B." The telescope should now be aligned for direction on the distant point, or, alternatively, on the vertical line cutting the point "T." If not, correct as follows:—

Remove the keep pins and loosen the nut of the clamping pin, which passes through the pivot of the sight bar, and the nut below the pivot with the spanner provided for the purpose. Then, with the spanner, turn the adjusting bush in the pivot until the pointer of the telescope and the vertical axis of the crosswire in the gun are parallel. Tighten up the nut and clamping pin and replace the keep pins.

(3) *To ascertain whether the sight clinometer is in adjustment.*

Set the "Sight clinometer" at zero. Place the "Bar, testing sights," on the open sights. Set a clinometer at zero on the "Bar, testing sights," and bring the bubble central by turning the elevating handwheel on the left side of the gun. The bubble of the "Sight clinometer" should now be at the centre of its run. If not, adjust as follows:—

Turn the worm spindle of the "Sight, clinometer" until the bubble is central, then, with spanner No. 244, loosen the screws securing the indicator plate, and slide the plate until the indicator reads zero. Carefully tighten the securing screws, making sure that the indicator is not again moved. Next observe the zero point of the micrometer collar at each end of the worm spindle, and if any error is apparent, loosen the securing nuts with the spanner (No. 244), turn each micrometer collar till its zero is correct, and re-tighten the nuts.

(4) *To ascertain whether the range dial is in adjustment.*

Place a clinometer set at zero on the muzzle end of the guide ribs, and bring the bubble central by turning the elevating handwheel on the right side of the gun. If the range dial does not read zero range, remove the split pin on the end of the dial spindle and slack back the nut about four turns by means of a McMahan spanner until the ring is free. Then make the zero of the ring coincide with the pointer, and screw up the nut by hand. Before tightening it up, see that the bubble is still central.

It is essential that the sight line should remain horizontal during this operation. Care should therefore be taken not to touch the handwheel on the left side of the gun, and a clinometer should be placed on the bar testing sight to finally check that it is still horizontal.

By placing the clinometer on the guide ribs of the gun at the muzzle end and adjusting the range dial to agree, the "droop" of the gun is allowed for.

#### DIAL SIGHT NO. 7 AND NO. 2 CARRIER.

##### (a) *Direction.*

*Test.*—Lay the axis of the gun on the distant point, or point "B" of the target. Set the dial sight, deflection scale of the carrier, and

INDICATOR, FUZE, Q.F. 18 PR. MARK II.

SCALE = 1/4.

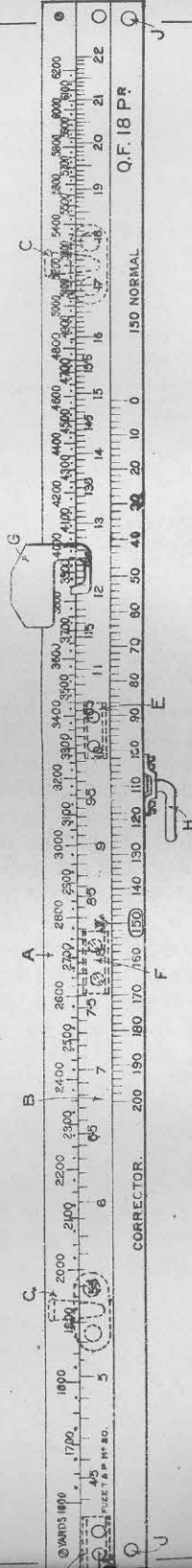

- A. BASE PLATE.
- B. SLIDE
- C. HOOK
- D. STOP SLIDE END.
- E. " " CENTRE.
- F. STOP BASE PLATE.
- G. READER.
- H. HANDLE, CLAMPING.
- J. STUD, BASE PLATE.
- K. " " SLIDE.

drum of the rocking bar sight at zero. Place the carrier with dial sight attached in its bracket on the elevating arc bracket and clamp at a convenient height. The vertical line in the dial sight should be on the distant point, or on a vertical line 8.5 ins. to the left of the point B on the target.

*Adjustment.*—If it is not, loosen the clamping nuts on the ends of worm spindle of the deflection scale of the carrier, turn the milled heads until the vertical line in the sight is laid on the correct point, and whilst preventing the milled heads from turning, revolve the adjustable drums with minute graduations until they read zero. Tighten up the clamping nuts. If the reader of the degree scale on the carrier is not at zero, loosen the two screws beneath it, and shift the reader plate to one side until it is so. Tighten up the two screws.

If sufficient adjustment cannot be given on the carrier, which allows of about  $1\frac{1}{2}^{\circ}$  to either side, the remainder must be put on the dial sight in a similar manner. The micrometer drums are similar, and the reader plate can be moved to either side when the two screws in it are slackened.

(b) Elevation.

*Test.*—Lay the telescope sight on the distant point. (It is not satisfactory to test the elevation on the target, as, owing to the carrier being adjustable for height, no definite point can be marked on the target for laying on.) Set the vertical scale at the top of the dial sight at zero. The horizontal line in the telescope should be on the distant point.

*Adjustment.*—If it is not, turn the micrometer head on the top of the sight until the horizontal line is on the distant point, loosen the clamping cap on the top of it, and whilst preventing the milled heads from turning, revolve the adjustable drum with minute graduations until it reads zero. Tighten up the clamping cap. The reader of the degree scale cannot be adjusted. If it is much out it should be re-engraved.

INDICATOR, FUZE, MARK II.

(Plate XV.)

The indicator consists of the following principal parts:—base plate, slide, slide clamp, reader and stop screws.

The base plate is of delta metal about  $34\frac{1}{2}$  inches long, graduated on the upper portion with a yard scale, and on the lower with a corrector scale; it is grooved in the centre to receive the slide, which is graduated with a fuze scale.

The corrector scale is divided into divisions reading up to 200, 150 being the normal.

The slide can be clamped in any position desired by means of the clamp, which is attached to the base plate. The yard and fuze scales are read by the reader, which is free to move along the base plate, but it is prevented from coming off the base plate by stops. Attached to the reader is a small spring which can be manipulated by a screw for taking up any play in the reader due to wear.

Two indicators per sub-section will be carried, one on the shield of the carriage and one on an ammunition wagon at the rear.

### LIMBER, Q.F. 18-PR., CARRIAGE, MARKS I AND II.

(Plates XVI and XVII.)

The Mark I limber consists of a steel frame, a limber hook, a second class axletree, draught fittings, an ammunition box, and two field wheels.

The frame consists of four futchels, connected at the front end by a plate, and at the centre by stays. Platform and foot boards are fitted to the top, and draught hooks for the swingletrees to the front of the outer futchels. A steel limber hook, No. 31, is riveted to the rear end of the inner futchels.

The axletree, No. 208, is of weldless steel tube: it is fixed by flanges to the futchels. The linch pin and adjusting collar are similar to those for the carriage.

The fittings for draught consist of a No. 17 Mark III pole, a No. 3 supporting bar, and two No. 11 swingletrees. The pole and bar are for use with the R.A. pole draught breast harness. The pole is 12 feet  $4\frac{1}{2}$  inches in length over all; the front end is protected by steel wrapping plates; a U-shaped tug is passed through the pole from the underside and secured by a nut on the top. The tug forms a stop for the pole bar, and its position from the point of the pole may be varied from 14 $\frac{1}{2}$  inches to 29 $\frac{1}{2}$  inches, in distances of 3 inches, according to requirements. The pole bar is 3 feet  $9\frac{1}{2}$  inches in length, fitted at the centre with a circular loop, which is formed to pass over the front end of the pole and butt against the tug. Two links are fitted on each side of the loop, by means of which the bar is attached to the neck piece of the harness. The swingletrees are 2 feet 6 inches long.

The ammunition box is of steel, and opens at the rear; it is constructed to carry 24 rounds of "fixed" ammunition, is fitted with guard irons, Nos. 25 "near" and 26 "off," is secured to the frame by rivets, and supported by side connecting plates and gusset plates. Internally it is fitted with 24 tubular baskets secured by leather stops, or brass tubes fixed horizontally. A compartment is formed in the centre for two wood trays for small stores. The lid (the inside of which is covered with a leather pad to prevent the ingress of water) is hinged to the bottom of the box, and is provided with a shield plate of the same width, which hangs vertically below the lid when opened. The shield plate is hinged to the lid, and, when closed, the former is folded over the latter, which is secured by catches on each side of the box.

Spring clips are attached to the front of the box for carrying two rifles, in canvas covers, secured in position by means of "quick release" securing straps.

The limber is fitted on the underside with wire net receptacles for carrying canvas water buckets, with fittings to carry a 3-lb. grease tin, and two No. 3 lubricating cans (one for Rangoon and one for buffer oil); also various stores as shown in Packing Diagram A, page 45.

LIMBER, Q.F. 18 PR. CARRIAGE, MARKS I AND II.

SIDE ELEVATION.

INS. 12 9 6 3 0 3 FEET.

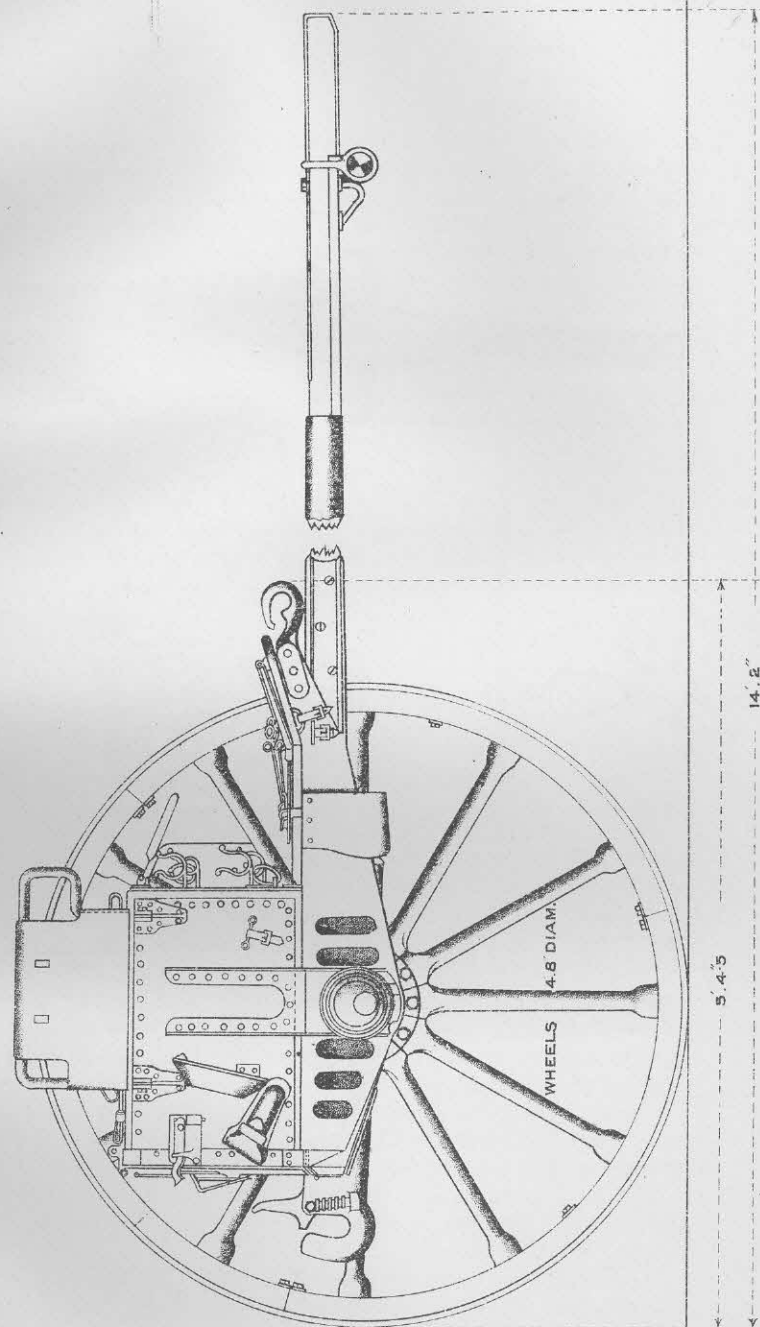



LIMBER, Q.F. 18 PR. CARRIAGE, MARKS I AND II.

REAR ELEVATION.

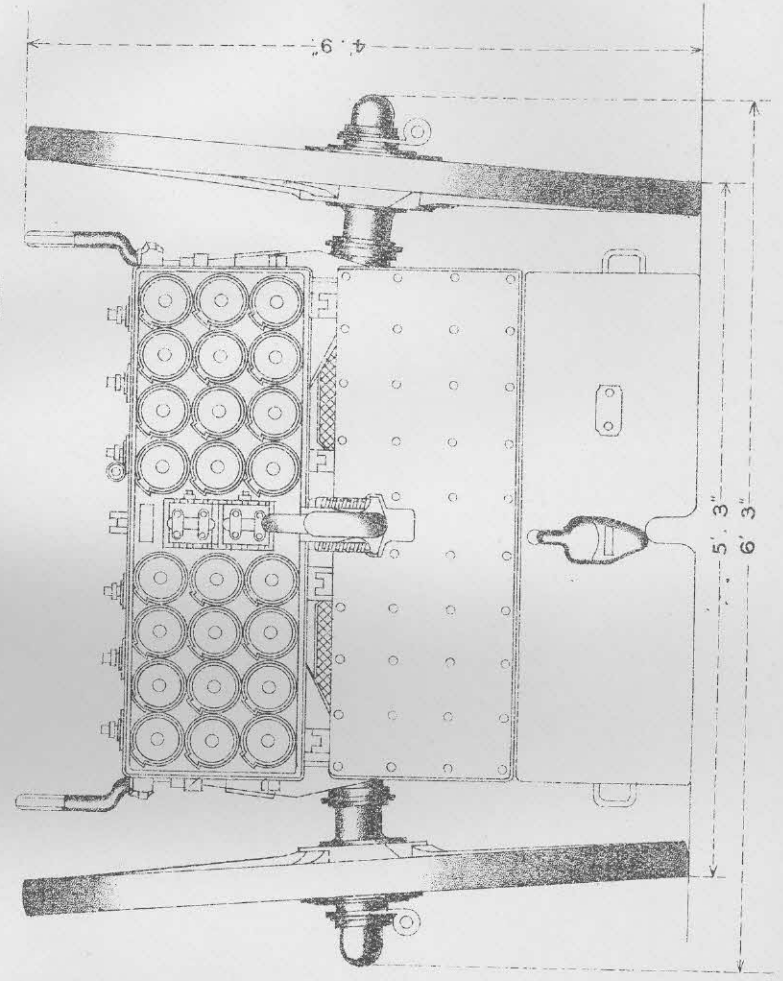

# LIMBER, Q. F., 18 PR WAGON, MARKS I AND II.

SIDE ELEVATION.

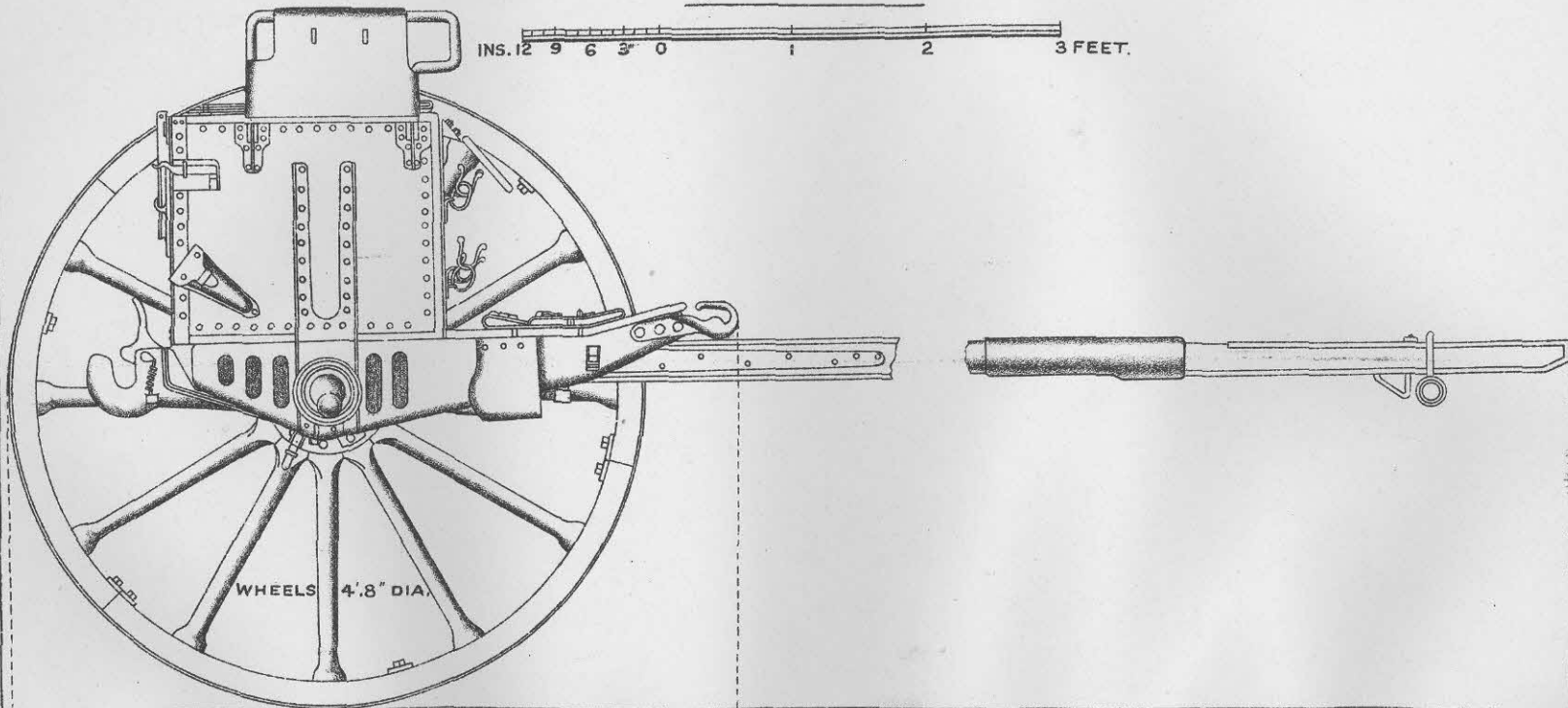
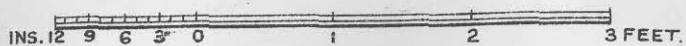

WHEELS 4'.8" DIA.

5'.4"5

14'.2"

LIMBER, Q.F., 18 PR., WAGON, MARKS I AND II.

REAR ELEVATION.

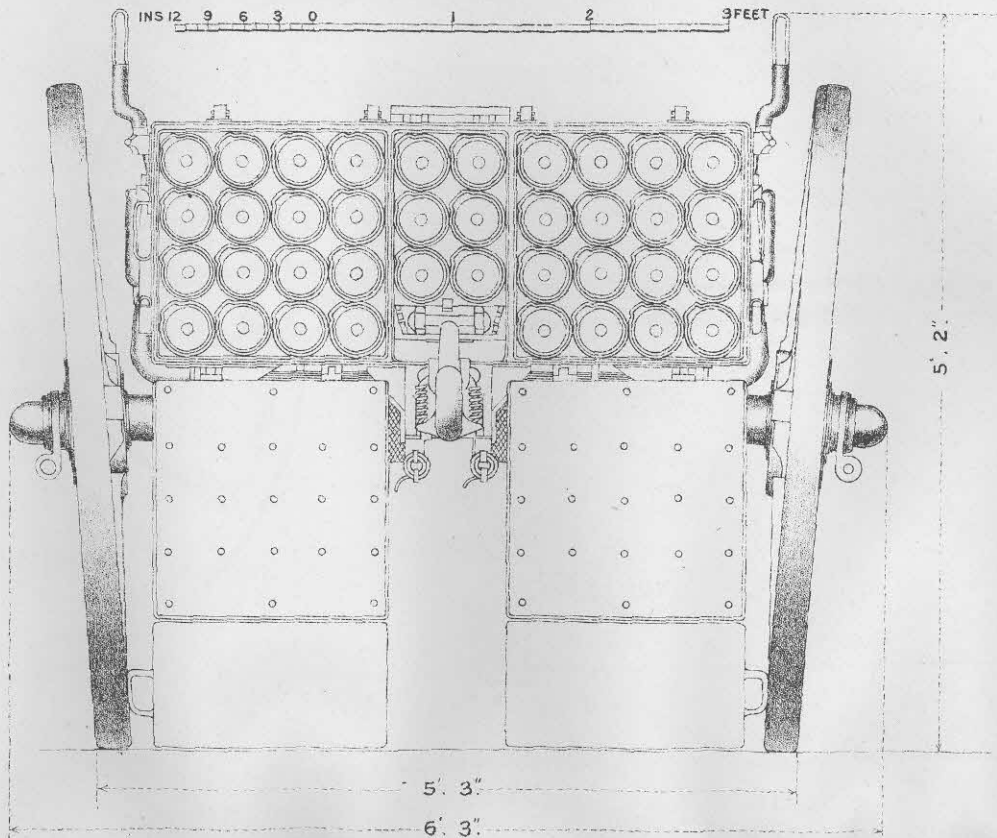

## WAGON AMMUNITION, Q.F., 18 PR., MARKS I AND II.

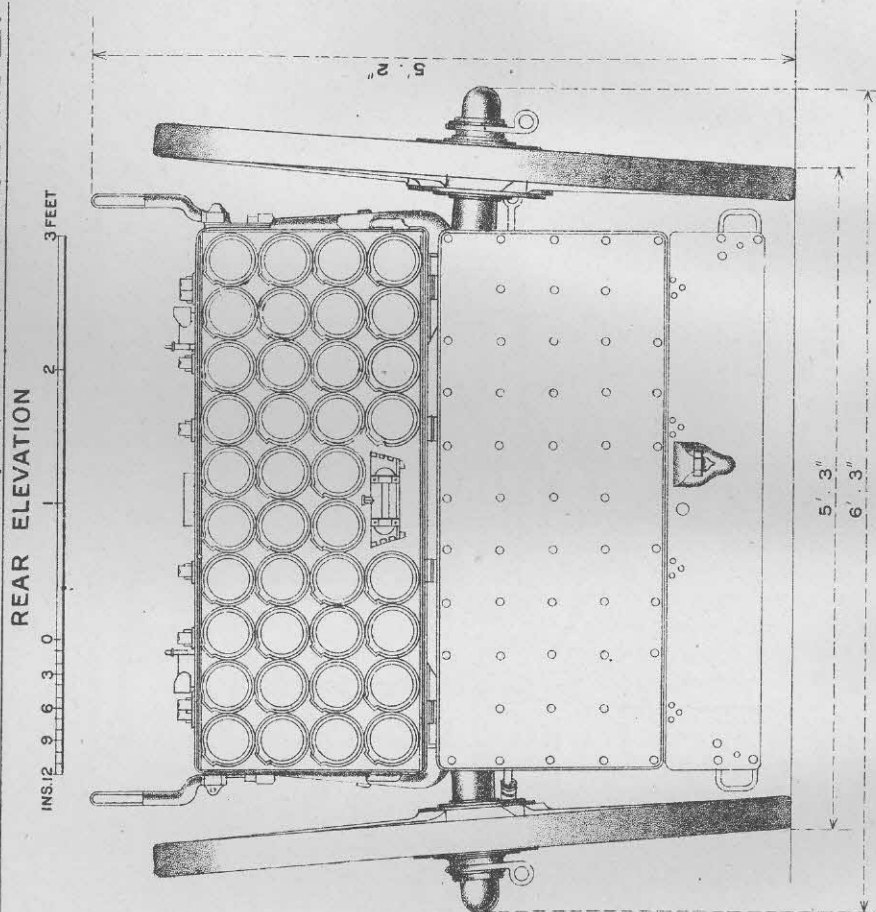

The Mark II limber differs from Mark I only in being fitted with tubular baskets instead of brass tubes for carrying the ammunition.

The wheels are the same as those described for the carriage.

Half the limbers per battery will be fitted with loops for kicking straps.

## LIMBER, Q.F. 18-PR., WAGON, MARKS I AND II.

(Plates XVIII and XIX.)

The wagon limber differs from the carriage limber principally in the form and capacity of the ammunition box, which is constructed to carry 38 rounds, and one tray for small stores. It is provided at the rear with three lids, one on each side, and one in the centre. The side lids are fitted with shield plates, and hang below the limber frame, as in the carriage limber; the centre lid is hinged at its upper edge, and rests on the top of the box when open.

## WAGON, AMMUNITION, Q.F. 18-PR., MARKS I AND II

(Plates XX and XXI.)

The Mark I wagon consists of a steel frame, a hollow box perch fitted with a perch eye, a steel ammunition box, a brake gear, a 2nd class axletree, and two field wheels.

The frame consists of two flanged sides connected by stays; platform and foot boards are fitted to the sides and perch in front, and a shelf is fitted under the platform board on each side of the perch to carry a 14-lb. grease box.

The perch, which is connected to the frame by the side stays and platform boards, is plugged at the front end with hard wood. It is fitted with locking plates and a No. 13 perch eye.

The ammunition box is the same as for the wagon limber, with a shield plate similar to that for the carriage limber. Fittings are also provided for the fuze indicator.

A tire brake is provided, which acts on the front of the wheels and is actuated from the rear by a hand wheel.

The wagon is fitted to carry a spare jointed pole and the various stores as shown in Packing Diagram B, page 46.

The axletree is 2nd class "C" No. 208. The wheels are similar to those for the wagon limber.

The Mark II wagon differs from Mark I only in being fitted with tubular baskets instead of brass tubes for carrying the ammunition.

*Note.*—To facilitate the extraction of ammunition from the baskets the leather work of the basket should be kept soft by grease. The baskets will be tested periodically and if necessary, rectified by the insertion of a dummy round.

DIMENSIONS, &c.

	Carriage and Limber.		Ammunition Wagon and Limber.		
	ft.	ins.	ft.	ins.	
Height {	to axis of gun .. .. .	3	0.86	—	
	to line of telescope .. .. .	3	8.01	—	
	to line of sight .. .. .	3	9.11	—	
	maximum { carriage, without dial sight .. .. .	4	8.75	—	
	{ limber .. .. .	4	9	—	
	{ wagon and limber .. .. .	—	—	5 2	
Width, maximum.. .. .	6	3	6	3	
Length of {	carriage with gun .. .. .	13	8	—	
	limbers { carriage { with pole .. .. .	14	2	—	
		{ without pole .. .. .	5	4.5	—
	wagon { wagon { with pole .. .. .	—	—	14	2
{ without pole .. .. .		—	—	5	4.5
	between axletrees .. .. .	9	11	7	4.75
Length {	with pole (end of pole on ground) .. .. .	27	4.5	21	5.5
	without pole .. .. .	18	9	12	11
Greatest projection beyond track of wheels .. .. .	—	6	—	6	
Wheels {	track .. .. .	5	3	5	3
	height .. .. .	4	8	4	8
Space required to turn in .. .. .	32	0	28	0	
Angle of {	lock .. .. .	deg.	min.	deg.	min.
		71	0	64	0
	trail (spade buried) .. .. .	14	18	—	—
		39	30	35	30
Upsetting angle .. .. .	16	0	—	—	
Elevation, maximum .. .. .	5	0	—	—	
Depression, maximum .. .. .	—	—	—	—	
Telephone Wagon.					
Body {	height .. .. .	—	—	ft.	ins.
	length .. .. .	—	—	4	8
	width (maximum) .. .. .	—	—	9	10
Lir ber {	height .. .. .	—	—	6	4
	length { with pole .. .. .	—	—	5	6
		{ without pole .. .. .	—	—	14
	width (maximum) .. .. .	—	—	5	3
Body and limber {	length { with pole .. .. .	—	—	6	4
		{ without pole .. .. .	—	—	23
	length between axletrees .. .. .	—	—	14	2
	space required to turn in .. .. .	—	—	7	7
	angle of lock .. .. .	—	—	28	6
upsetting angle .. .. .	—	—	—	62°	
Wheels {	height .. .. .	ft.	ins.	—	32°
		—	—	4	8
		—	—	5	3
track {	body .. .. .	—	—	5	3
	limber .. .. .	—	—	5	4

AVERAGE WEIGHTS.

(Fully packed with ammunition and stores, but without men or personal equipment.)

	Weights.			
	cwt.	qr.	lb.	
Carriage with gun .. .. .	25	0	21	
Limber { carriage .. .. .	15	1	0	
	{ wagon .. .. .	19	0	0
Wagon, ammunition { with spare jointed pole .. .. .	19	3	17	
	{ without spare jointed pole .. .. .	19	1	17
Carriage and gun with limber .. .. .	40	1	21	
Wagon, ammunition, and limber { with spare jointed pole .. .. .	38	3	17	
	{ without spare jointed pole .. .. .	38	1	17
Carriage and limber { weight on fore wheels .. .. .	16	0	21	
	{ weight on hind wheels .. .. .	24	1	0
Wagon, ammunition, and limber {	weight on fore wheels with spare jointed pole .. .. .	20	2	5
	weight on hind wheels with spare jointed pole .. .. .	18	1	12
	weight on fore wheels without spare jointed pole .. .. .	20	0	14
	weight on hind wheels without spare jointed pole .. .. .	18	1	3
Weight on pole at tug 3rd hole from front end (limbered up) { carriage and limber { without men .. .. .	—	—	24	
	{ with 2 men on limber .. .. .	—	1	4
Carriage— { wagon and limber { without men .. .. .	—	—	20	
	{ with 2 men on limber .. .. .	—	1	0
Pressure of trail on ground .. .. .	1	0	8	
Pressure of trail on limber hook .. .. .	—	3	4	
Wagon, ammunition— { with spare jointed pole .. .. .	1	3	16	
	{ without spare jointed pole .. .. .	1	3	4
Pressure of perch { with spare jointed pole .. .. .	1	0	20	
	{ without spare jointed pole .. .. .	1	0	0
Wheel, 2nd Class "C" { No. 43 .. .. .	1	2	10	
	{ „ 45 .. .. .	1	3	10
Telephone wagon {	limber without stores .. .. .	6	1	0
	limber complete with stores .. .. .	8	2	13
	body without drums and stores .. .. .	7	0	0
	body complete with stores .. .. .	9	1	0

SEPARATE DEMANDABLE STORES.

APPARATUS, ADJUSTING RUNNING OUT SPRINGS, Q.F. 18-PR., MARK I.

The apparatus consists of a steel screw with locking nut, clip, and actuating nut with handle. The method of attaching the apparatus to the hydraulic buffer is as follows:—

- (a) Insert the V-screw thread on the screw into the hole for its reception in the rear end of the controlling plunger as far as it will go (care being taken that the locking nut is screwed back against the collar on the screw), and tighten up the locking nut against the face of the plunger.
- (b) Place the clip over the screw, and insert the two studs into corresponding holes in the rear of the spring case.
- (c) Screw the actuating nut, with handle, against the rear end of the clip.

FUNNEL, FILLING HYDRAULIC BUFFER, MARK II.

The funnel, which is of leather, is for use in filling the cylinder of the hydraulic buffer.

SYRINGE, Q.F. 13 AND 18-PR., MARK I.

The syringe is for extracting liquid from the hydraulic buffer (*see* Care and Preservation in "Regulations for Magazines and Care of War Matériel").

TOOLS, PACKING GLAND, Q.F., 18-PR.—

COLLAR, MARK I.

PLUG, MARK I.

The collar and plug are for use in packing the stuffing box of the hydraulic buffer.

The collar is for assisting the asbestos packing ring over the shoulder of the piston rod.

The plug is for removing the packing and supporting rings, and packing washers, from the stuffing box.

TOOL, WITHDRAWING RING SUPPORTING PACKING, Q.F. 13 AND 18-PR., MARK I.

The tools are for withdrawing the outer ring supporting packing from the stuffing box of the hydraulic buffer.

WAGON, GENERAL SERVICE, MARKS IX TO X\*.

The Mark IX wagon consists generally of the following parts:—body, under carriages, seat, floating raves, brake, axletrees, and wheels. It is fitted with a 4-inch roller scotch, whip socket, and two grease boxes.

The body is separate from, but rests on, front and rear under carriages. Allowance is made on the front carriage for slight longitudinal motion, to ensure flexibility to the vehicle for rough travelling. The rear under carriage has two straight guides, which are continued slightly beyond the body.

A locker is formed on the front part of the wagon; the locker is bevelled off to allow the fore carriage to have a greater sweep, and thus minimise the space in which the wagon can turn.

The wagon is fitted for pole draught, which consists of a No. 7A pole and two No. 10A or 11 swingletrees.

The splinter bar is strengthened by iron stays, which are formed with hooks at the front for the attachment of the swingletrees.

The driver's seat is supported on elliptical springs, to afford easy riding; the springs are fitted to a cross bar, with ends formed to fit over two wooden standards, and are kept from being too lively by two leather straps, the seat being fastened to the standards by keys.

The brake, which acts on the rear of the hind wheels, is applied from the driver's seat by a hand lever, or from the rear of the wagon by a handle operating a screw. The hand lever is connected by a flexible wire rope on the offside of the wagon to a lever, secured to the guides of the rear under carriage, and fitting into a loop attached to the rear axletree bed. A brake screw is connected with this lever and a wooden cross bar, which carries the brake blocks, and which is

# WAGON, TELEPHONE, MARK I.

LIMBER AND BODY.

— TYPICAL —



INCHES.

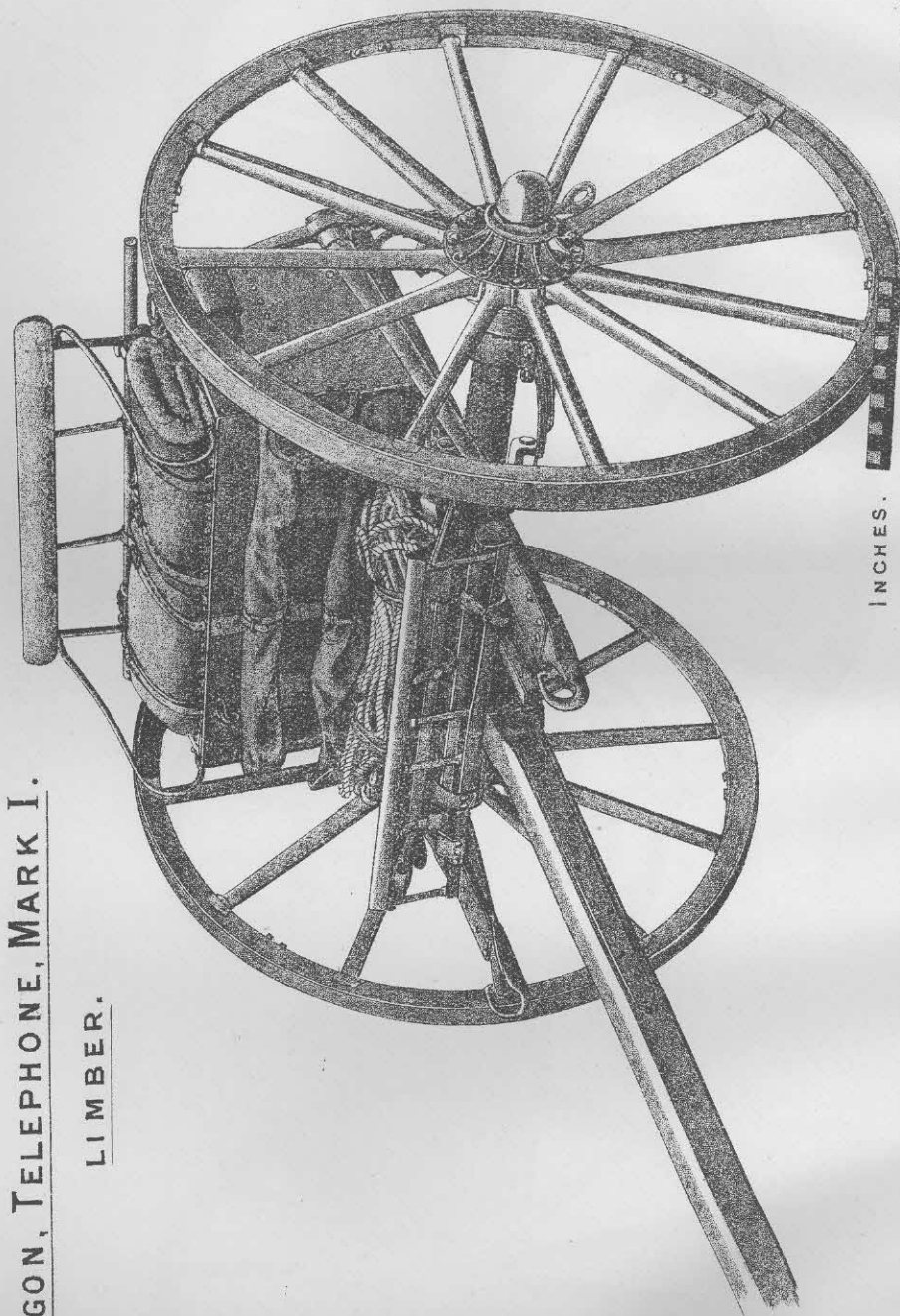

WAGON, TELEPHONE, MARK I.

LIMBER.

supported by brackets secured to the end of the guides. When the hand lever is pushed forward, the blocks are forced against the wheels. A rack retains the hand lever in position when the brake is applied, and a spring fixed behind the lever serves to ease the blocks off the wheels when the hand lever is released.

The fore axletree is 3rd Class "B," No. 174, and the hind, 2nd Class "C," No. 200. The wheels are 3rd Class "B," No. 159, and 2nd Class "C," No. 200, being 3 feet 9 inches and 4 feet 8 inches in diameter, respectively, with 2½-inch tire.

The cover is made of waterproof canvas, and can be adjusted to suit varying heights of loads, having on the outside two rows of tabs with eyelet holes, and on the under side, and the hem side, lines of white rope. Brass eyelets are secured at intervals along the hem.

The cover is secured to fitments on the wagon by lashings, which should be passed through a row of eyelets on each side and on the back, according to the height of load to be covered.

The side lines of white rope on the under side are for use in reefing the cover when small loads are carried in the wagon; the four on the hem are to keep the cover clear of the wheels.

The sides and rear of the cover not required should be rolled up and stowed away inside, the front portion being stowed behind the driver's seat on full and half-loads.

Weight	...	...	...	...	...	...	16 cwt. 3 qrs. 25 lbs.
Minimum space in which the wagon can turn	...	...	...	...	...	...	39 ft.
Tonnage { for shipment	...	...	...	...	...	...	6'54 tons.
Tonnage { for transport in boats	...	...	...	...	...	...	10'112 tons.
Rectangular space occupied in boats	...	...	...	...	...	...	12 ft. 8 ins. x 6 ft. 0½ in. x 5 ft. 3 in.

Mark X is generally similar to Mark IX, but of rougher make, and is fitted with a sweep bar. Weight, 15 cwt. 2 qrs. 17 lbs.

Mark X\* is the Mark X wagon provided with dust capped wheels and fittings, Nos. 200A (hind) and 159A (fore). Weight, 15 cwt. 3 qrs. 12 lbs.

WAGON, TELEPHONE, MARK I.  
(Plates XXII and XXIII.)

The wagon consists of body and limber and is constructed to carry electric cable on drums, and other stores for field telephone operations, as shown in the diagram of packing, page 47.

BODY.

The body consists principally of a framework of steel plate with perch and axletree, mounted on two wheels and fitted with brake and winding gear. The framework consists of four futchels (two inner and two outer) held together by front and rear crossbars, the connecting stays being secured to the axletree by flanges. The two inner futchels are prolonged at the front to form a perch to which a perch eye is fitted. Locking plates are riveted to the inner futchels at the front. The operator's seat and footrest are fitted at the rear of the wagon on the near side. There are also two pole guard handles fixed at the rear.

The cable drums are of steel plate and are carried three on the near and three on the off side—the front and rear pair each carrying one mile of D 3 electric cable.



Brakes for front drums are fitted, one on each side, to regulate the speed of the drums when travelling. They are of the screw pattern and are actuated from the rear by a handwheel.

The winding gear is fitted to the near side of the wagon and consists of sprocket wheel and pinion and roller chain. The sprocket wheel is actuated by a pawl engaging into a bracket\* secured to nave of near wheel. The driving strap is adjusted by means of a screw connected to the carrier and is actuated by a handwheel; by this arrangement of the gearing, the gear can be connected, or disconnected, with either the centre or rear drum on the near side. A drum must be in either of these positions to be operated by the gear. Each drum is interchangeable. When winding in the cable, if the speed of the drum is too fast, it can be regulated by slackening the band by means of the actuating handle, so that the band may slip slightly.

The axletree is 2nd Class "C," No. 194 and the wheels No. 198A.

The brake gear is of the screw pattern actuated from the rear; the bar is of tubular steel suspended from the frame by steel links, attached to brackets which are riveted to the frame; the brake blocks are of cast iron.

Eight telegraph poles are carried on the centre portion of the frame, resting at the rear end on top of, and strapped to, the rear crossbar and passing under the front crossbar, the ends rest on a leather padded steel plate, to which the poles are also strapped.

A field telegraph ladder is carried under the body of the wagon secured by straps.

#### LIMBER.

The limber consists principally of a framework with axletree and springs, a box, and draught fittings mounted on two wheels.

The framework consists of four futchels (two inner and two outer) connected by plates; draught hooks are fixed to the front end of the outer futchels and a No. 32 limber hook to the frame at the rear.

The box is made of steel plate and is riveted to the frame. It is divided into compartments for carrying the portable telephones, electric cells and other stores. The top is fitted with a back rest and guard irons, which together form a seat.

The wheels and axletree are the same as for the body.

The draught fittings consist of a Mark III No. 17 pole, a Mark II No. 3 bar, supporting pole, and two No. 11 swingletrees.

For particulars of stores carried both inside and outside, see list of stores, pages 43 and 44, also packing diagram C. Strapping is provided both on the limber and wagon for securing those stores which are to be carried externally.

#### SPECIAL PRECAUTIONS.

With a keyless limber hook, the limber is not prevented from turning over, when unhorsed, by a limber hook key; therefore, to prevent accidents, when a vehicle (having this form of limber hook) is limbered up, the pole must not be allowed to rise above the horizontal unless it is kept under proper control.

\* This bracket will be regarded as a component of the wagon and attached to the wheel as required so that the interchangeability of the wheel will not be affected.

## CARE AND PRESERVATION OF CARRIAGES, &c.

See "Regulations for Magazines and Care of War Matériel."

### LIST OF LUBRICATING HOLES.

Fittings which are provided with oil holes for lubricating purposes.	No. of Holes.	Position of Holes.
CARRIAGE.		
Capsquares (2) ... .. each	1	
Carriage body—		
Bearings, axletree (2) ... .. "	1	In lubricating cup, 1 on each side.
" clutch spindle (2) ... .. "	1	Inside carriage body, 1 on each side.
Cap, lower bracket of elevating gear	2	In bearing portion for handwheel spindle on left side.
Cradle—		
Body ... ..	8	7 in sides for oiling sliding surfaces, and 1 on left side at rear, with tube for lubricating handwheel spindle.
Bearing, pinion, spindle handwheel	1	On right side close to handwheel.
Gear brake—		
Bolts, connecting—		
{ cranked levers (3), each	1	2 on left side and 1 on right, close to shield.
{ eccentric link ... ..	1	In head of bolt, right side
{ fork actuating screw ...	1	In head of bolt, left side
		} near brake blocks.
Fork, actuating screw ... ..	1	On right side.
Link, eccentric ... ..	1	On left side.
Gear, elevating—		
Rod, connecting elevating screw ...	1	In lower end.
Gear, firing—		
Arm, connecting ... ..	1	In upper end, left side.
Rod, connecting ... ..	2	1 at each end, left side.
Bracket, connecting arc, range gear ...	1	On left side.
Bolts connecting brake arms (2) each	1	In head of each bolt.
Crosshead, traversing gear ... ..	1	
Lever, traversing ... ..	1	At jointed end of lever, near plunger.
Sight, rocking bar ... ..	1	For oiling arm trunnion supporting sight.
Wheels, 2nd Class, "C," No. 45 (2) each	1	In inner flange.
WAGON, AMMUNITION.		
Levers, cranked brake gear, { near... { off ...	1 1	} Rear of wagon.

NOTE.—In order to assist in identifying the position of the lubricating holes, the heads of the screws should be kept free from paint.

## AMMUNITION.

Description.	Mark.	Weight of Cartridge Case with Primer.		Charge.		Shell.			Nature of Fuze.	Total Weight of complete Round.	Means of Firing.	
						Mark.	Bursting Charge.					Weight filled and fuzed.
							Nature.	Weight.				
Cartridge Q.F. 18-pr.—Shrapnel	I	lb.	oz.	lb.	oz.	I, II and III	R.F.G. <sup>2</sup> , blank F.G. new, S.F.G. <sup>2</sup> , or Q.F.F.G. R.F.G. <sup>2</sup>	oz. drs.	lb. oz.	T. & P., No. 80	lb. oz.	
		2†	15	1	6 $\frac{1}{2}$ $\frac{5}{8}$			2 8*	18 8		22 13 $\frac{1}{2}$ $\frac{5}{8}$	
Star ..	I	2†	15	0	8	I		0 3 $\frac{1}{4}$	10 3	Time, 15 secs., No. 25	13 10 $\frac{1}{4}$	
Blank, 1 lb., blank, L.G.	I and II	2†	15	1	0	—	—	—	—	—	—	
Blank, 7 oz., smokeless blank	I	2†	15	0	7	—	—	—	—	—	—	

\* Includes powder pellets, weight  $\frac{3}{4}$  oz.

† A certain number of "light" cartridges have been issued, the cases of which weigh 2 lb. 5 oz. each.

# CARTRIDGE, Q.F. 18 PR. SHRAPNEL, MARK I.

SCALE =  $\frac{1}{3}$ .

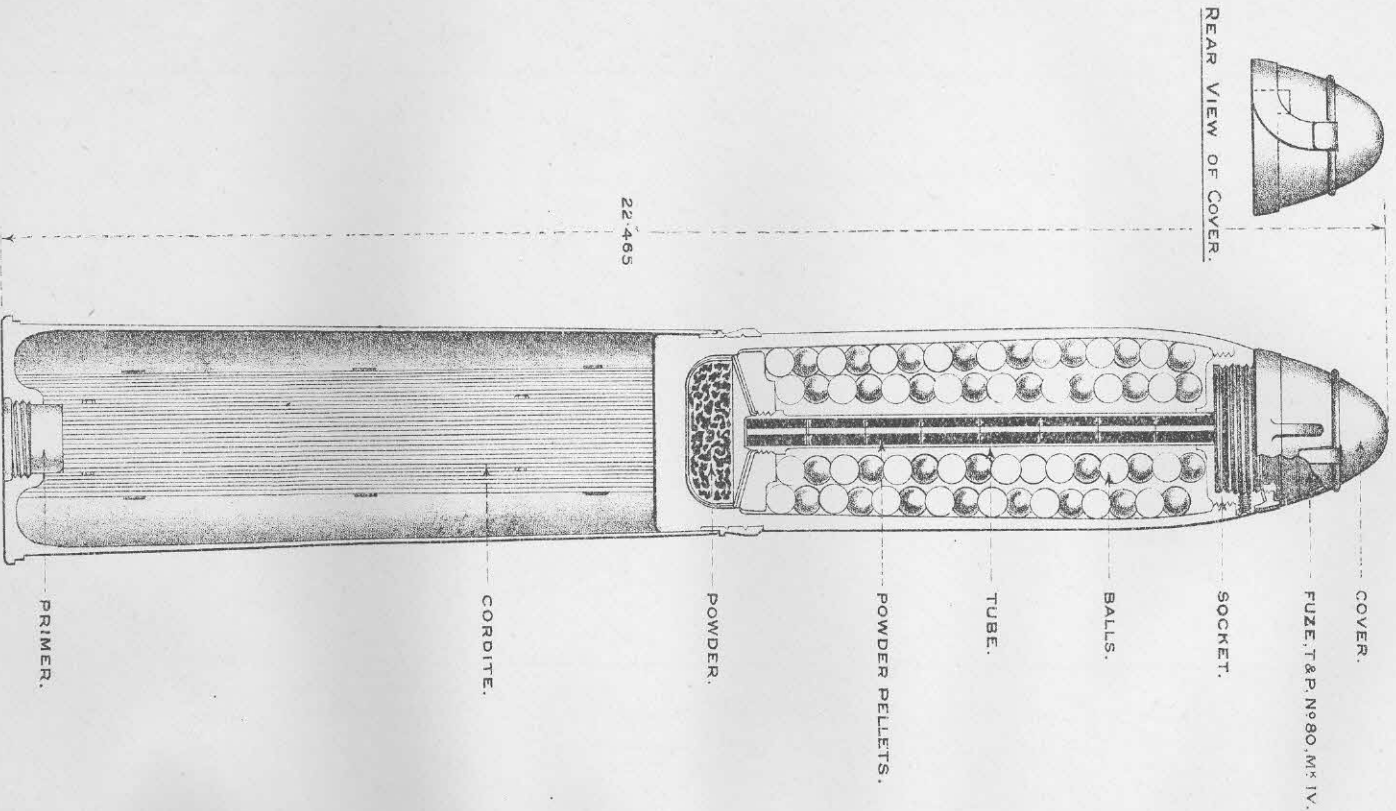

## PRIMER, PERCUSSION, Q.F. CARTRIDGES, N<sup>o</sup> I.

SCALE =  $\frac{1}{1}$ .

### MARK I.\*

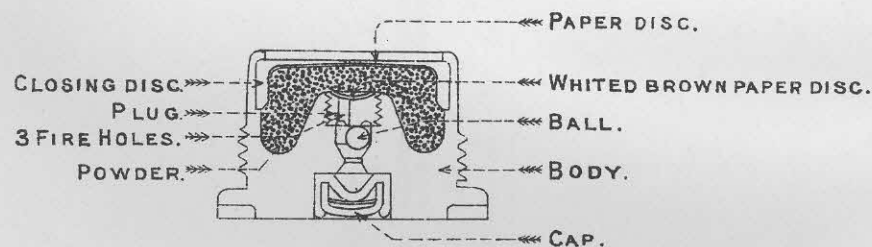

### MARK II.

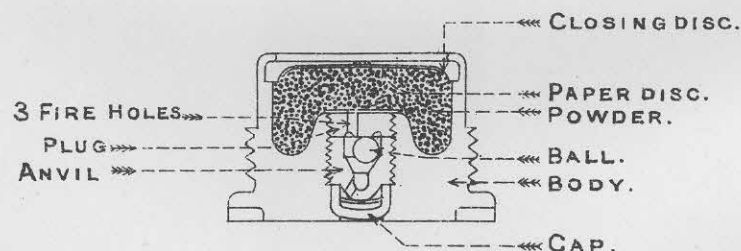

## GENERAL INSTRUCTIONS FOR CARE AND PRESERVATION OF AMMUNITION.

The following points should receive special attention:—

- (a) Care must be taken not to injure the cartridge cases or fuze covers when withdrawing the rounds from the four round boxes or the vehicles.
- (b) The rounds should not be carried by the clip tapes nor rested on the fuze covers.
- (c) The rounds should on no account be stacked on their ends, but on their sides, and then not more than two tiers high.
- (d) In cases where fuze covers have become detached, the rounds will be returned to the Army Ordnance Department.
- (e) When necessary, the shell should be wiped over with boiled linseed oil, care being taken to avoid the fuze.
- (f) Primers, if found to be unscrewed, should be tightened up.
- (g) As the time pellet with detonator lies near the point of the fuze and is protected only by the aluminium cap, rounds should be so handled as to avoid all risk of the fuze being knocked.

## CARTRIDGE, Q.F., 18-PR., SHRAPNEL, MARK I.

(Plate XXIV.)

The ammunition is fixed and a complete round consists of a cartridge case with percussion primer, charge, shrapnel shell, and fuze.

The case is of solid drawn brass, slightly tapered towards the mouth, and has a hole in the base screwed and recessed to take a percussion primer. The cases are black lacquered (formerly "dulled") so as to render them as inconspicuous as possible.

The charge consists of a 1 lb.  $6\frac{1}{8}$  oz. bundle of cordite M.D. size 8, recessed at one end to fit over the primer and the boss of the case, the other end being in contact with the base of the shell.

The No. 1 Mark II percussion primer (Plate XXV) consists of a metal body, screwed externally for a portion of its length to fit the primer hole in the cartridge case. The interior is bored and recessed to take a cap which is secured by a screwed plug; this plug has an anvil at one end, the other end being bored out to form a sealing chamber, and contains a soft copper ball to seal the escape of gas after firing and relieve the pressure on the cap. The sealing chamber is closed by a perforated screwed plug.

The body is filled with R.F.G.<sup>2</sup> powder, the mouth being closed with a brass closing disc having six radial slits.

Two small recesses are formed in the flange of the head for the primer key.

The Mark I\* primer (Plate XXV) differs from Mark II in the head being recessed to receive a brass chamber containing a cap. This cap chamber forms the anvil and has three fire holes; it is connected with the gunpowder charge in the body by a channel which contains a soft copper ball in a coned seating, and which forms the sealing chamber.

The Mark III shrapnel shell has a steel body with a recess in the base to contain the tin cup for bursting charge. The head of the shell is struck with a radius of two diameters, and is fitted with a

2-in. brass fuze socket. A brass tube containing perforated powder pellets conveys the flash of the fuze to the bursting charge, one end of the tube being fitted into the fuze socket, the other being screwed into a steel disc placed over the tin cup.

The shell contains 375 mixed metal bullets (41 per lb.) and is fitted with a copper driving band in a groove having two waved ribs.

The shell is secured in the case by the edge of the latter being pressed into the groove of the driving band. The shells are painted lead colour to distinguish them from the Mark I.

The *Mark II shell* differs from the Mark III in having a slightly narrower driving band. The shell is secured in the case by the latter being indented in four places into a cannellure turned on the shell, the cannellure being filled with Pettman's cement.

The *Mark I shell* differs from the Mark II in the radius of the head being  $1\frac{1}{2}$  diameters. The walls of the shell are thinner in the lower part, and the lid of the tin cup containing the bursting charge is also of a different shape. It contains 364 bullets.

Shell of early manufacture will take Mark I fuze covers only, but in later manufacture the fuze socket has been slightly modified, and such shell will take covers of later marks.

Mark I shell are painted black.

#### CARTRIDGE, Q.F., 18-PR., STAR SHELL, MARK I.

(Supplied when specially ordered only.)

The complete round consists of a cartridge case with percussion primer, charge, paper cylinder, star shell and fuze.

The *No. 1 Mark I\* or II percussion primer* described on page 33 will be used with this ammunition.

The *charge* consists of 8 oz. of cordite M.D. size  $4\frac{1}{4}$  in a circular bundle, recessed at one end to fit over the boss inside the case and to permit of the insertion on the percussion primer. It is held in position in the case by the perforated paper cylinder with two perforated discs at each end, an unperforated disc being also secured to the end that comes in contact with the cordite charge.

The *star shell* has a steel body recessed in the base to receive a bursting charge of  $3\frac{1}{4}$  drams R.F.G.<sup>2</sup> powder contained in a shalloon bag and threaded with quick match.

The head of the shell, which is fitted with a metal G.S. fuzehole socket, and a wood block, is attached to the body with 6 brass screws and 6 steel twisting pins.

A metal central tube, perforated with 12 fireholes, is screwed into a wrought iron diaphragm over the bursting charge and is fitted at the top into the fuze socket.

The interior of the shell, which is "velvrilled" and lined with brown paper, contains 10 stars in tiers of 5. A perforated iron disc separates the tiers, and is supported by wood supports which are placed between the stars in each tier.

The faces of the disc are covered with felt washers, and a felt washer is placed between the top of the stars and the wood block in the head.

The ribs of the groove for driving band are waved.

The "Fuze, time, 15 seconds, No. 25," will be used with this shell.

#### CARTRIDGE, Q.F., BLANK, 18-PR.

The Mark II blank cartridge consists of a service case and percussion primer with a charge of 1 lb. blank L.G. powder contained in a No. 1 class silk cloth bag, having three silk braid hoops and, together with a felt disc with lifting loop, enclosed in a felt jacket. The mouth of the cartridge is closed with a split paper ring and leather-board cup by means of the wood drift supplied for the purpose.

The Mark I blank cartridge differs from the Mark II in the bag having two hoops instead of three, and in having a shorter and narrower lifting loop.

#### CARTRIDGE, Q.F., BLANK, 18-PR., FILLED, 7-OZ., SMOKELESS, BLANK, MARK I.

This blank cartridge consists of a service case and percussion primer, with a charge of 7 oz. smokeless blank and about 4 oz. 5 drs. of matchwood shot. It is closed with a split paper ring and leather-board cup by means of the wood drift supplied for the purpose.

The empty cases for making up blank locally are issued 20' in a "Box, cartridge cases Q.F. 18-pr."

Instructions for making up blank and smokeless blank cartridges with charges issued for the purpose, as may be necessary from time to time, will be found on the lid of the box in which the empty cases are received.

#### CARTRIDGE, DUMMY, Q.F., 18-PR.

This dummy cartridge is for use in practising fuze setting. It consists of an empty service shell body secured in a service case in the usual manner and further secured by a bolt, one end of which is fitted into the primer hole of the cartridge and the other end screwed into the base of the shell.

The shell is fitted with a 2-inch fuze hole socket closed at the bottom, and is filled with a mixture of dust and lead ash.

The cartridge case contains a wood block which is recessed at one end to fit over the boss in the base. Four holes are bored in the side and three in the base of the case, for ready identification of the dummy cartridge.

#### CARTRIDGE, Q.F., 18-PR.—CASE DRILL.

The drill case consists of an empty service case with the mouth plugged with a hard wood disc about 1-in. thick, and of a diameter to ensure a good fit in the case. Six of these cases with a drill primer are allowed to Batteries for drill purposes generally.

The drill primer consists of a body of the same external shape as a service primer, but bored out to take a hard rubber plug which is held in position by a screwed plug. It is stamped "DRILL" on the head.

## FUZE, TIME AND PERCUSSION, No. 80.

(Plate XXVI.)

The Mark IV fuze is made of aluminium, except where otherwise stated, and consists of the following principal parts:—Body with brass ring, top and bottom composition rings, two waterproofed cloth washers, cap with set screw, base plug, time and percussion arrangements, and brass cover.

The lower portion of the body is screwed to receive a holder for the percussion arrangement, and the upper portion forms a stem containing the time detonator pellet and its stirrup spring. The shoulder or flange of the body is fitted with a brass ring, to the lower part of which the fuze cover is secured. The upper part of the brass ring is graduated from 0 to 22, each graduation being divided into 10 parts; a square notch is cut for the No. 17 Mark II fixing key, and a small cross to denote safety point. A recess is turned on the under side of the brass ring to fit over the nose of the shell, and is provided with a leather washer soaked in mineral jelly.

A pin is screwed into the lower time ring to form a projection by means of which the ring is set with the No. 18 setting key. A setting mark is cut on the ring.

The upper time ring is prevented from turning by two pins.

The cap is screwed on to the body over the upper time ring and closes the fuze. It is secured in position by a set screw.

The base plug is screwed externally to fit the bottom of the body.

The holder percussion arrangement carries the needles of both the time and percussion detonator. It is bored to receive the percussion detonator pellet, ferrule, stirrup spring, and spiral spring.

All the external joints, escape holes, &c., are waterproofed.

The cover is of brass, and consists of a cap, ring, tearing off strip, and strip securing ring.

The tearing off strip, having the brass ring attached at one end, is soldered round the cap, the brass ring being placed over the nose of the cap and held in position by the securing strip. The cap is soldered to the lower edge of the brass ring on the body of the fuze.

To remove the cover from the fuze, tear off the strip securing ring, then the tearing off strip, when the cap will fall off, leaving the fuze exposed.

The fuze when set full should burn, at rest, for about 22 seconds.

To set the fuze, turn the setting mark on the lower ring, by the setting key, opposite the graduation required.

*Action.*—Time arrangement. On shock of discharge, the detonator pellet sets back on the needle, straightening the clips of the time stirrup spring, firing the detonating composition and so igniting the composition of the top ring, which in succession lights that in the lower ring, and so fires the fuze.

Percussion arrangement. On shock of discharge, the ferrule sets back over the detonator pellet, straightening the clips of the percussion stirrup spring; the whole is then set free to move forward on impact or graze, and after compressing the spiral spring, the detonator upon striking the needle ignites the composition, and so fires the magazine.

Weight of fuze ... .. 10½ oz.

## FUZE, TIME AND PERCUSSION, No 80, MARK IV.

SCALE = 1/1.

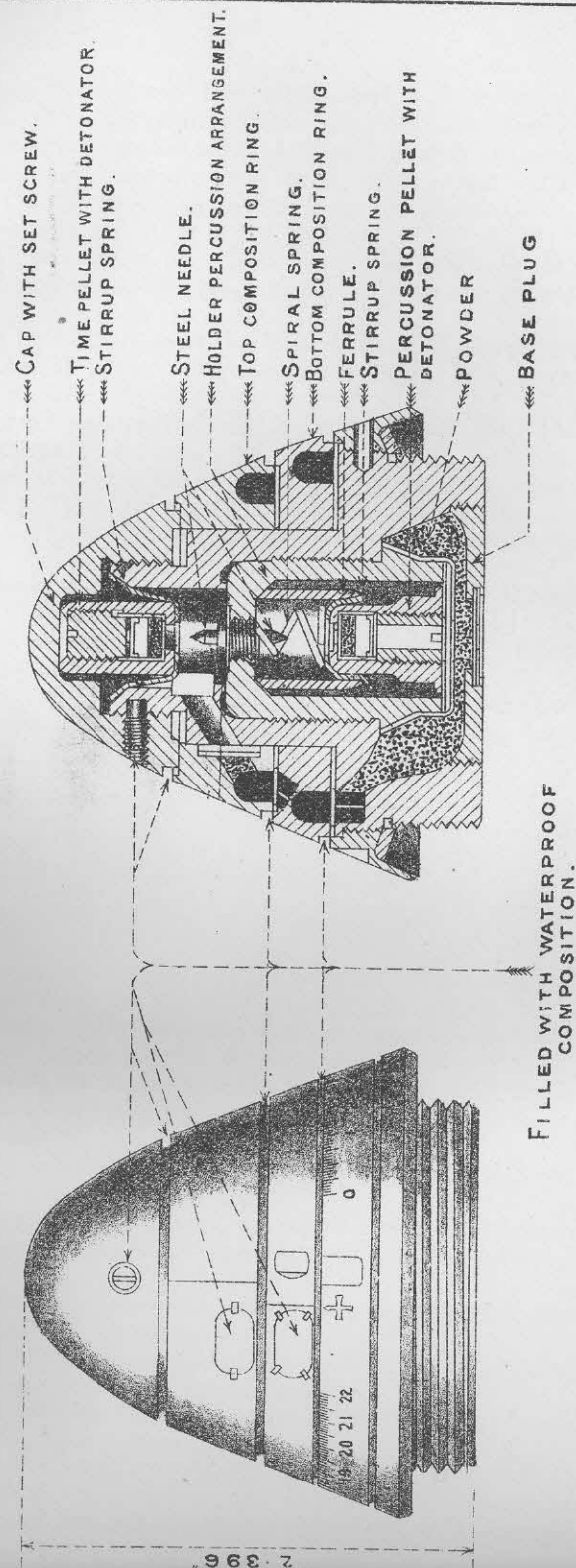

A tin cylinder to hold one fuze, if required, will be known as "Cylinder No. 80. F"; it is painted green and has yellow labels.

Some fuzes have been issued which bear no numeral, lot number, or date of manufacture, but are only marked on the cover with the design number (16603 A). They differ from the Mark IV in the shape of the brass ring and other minor details.

The Mark III fuze differs principally from the Mark IV in not having the brass ring round the flange of the body for the purpose of fitting the cap.

The Mark II fuze differs from the Mark III in not being waterproofed in its external joints. When existing Mark II fuzes have been waterproofed, they will be known as Mark II.\*

Fuzes that have been refilled will have the letter "R" placed after existing numeral.

Marks II and III fuzes are fitted with "Cover, fuze, time and percussion, No. 80, Mark II," which is of brass, and consists of the following parts:—Cap, a screwed ring with brass ring and tin band, and a washer.

The cap is shaped to fit over the fuze, and has a screw thread to engage with the thread on the screwed ring.

The brass ring is shaped to fit the nose of the shell, and is attached to the screwed ring by means of the tin band.

To remove the cover from the fuze, tear off the tin band, when the cap, together with the screwed ring, will fall off, leaving the fuze exposed.

Weight of cover ... .. 2½ oz.

#### FUZE, TIME, 15 SECONDS, No. 25.

The Mark III fuze is made of aluminium, and consists of the following principal parts, viz.:—Body, time ring, cap, safety pin, detonator pellet with detonator, stirrup spring, needle plug, magazine, bottom plug, and leather washer.

The lower portion of the body contains the magazine channel and magazine, and the upper portion forms a stem and contains the detonator pellet with detonator, and the needle plug. The shoulder of the body has a black mark to coincide with an arrow on the time ring, when set at safety.

The time ring, which is graduated from 0 to 44, is fitted round the exterior of the stem.

The cap fits over the time ring, on top of a steel spring washer, and closes the head of the fuze. It is secured, when in position, by a steel keep screw.

A copper safety pin, provided with a loop of red cord, passes through the top cap and the detonator pellet.

The detonator pellet is suspended by the safety pin and a stirrup spring, which is kept in position by its two clips.

The magazine contains about 45 grains of R.F.G.<sup>2</sup> powder, and is closed by means of the bottom plug.

The openings of the fuze are waterproofed to exclude damp.

*Action.*—On shock of discharge, the detonator pellet sets back, thereby straightening the clips of the stirrup spring, and being driven

on to the needle of the needle plug ignites the detonator, which fires the composition of the time ring, this burning till it reaches the magazine channel, thereby igniting the powder in the magazine.

Weight ... .. 5 $\frac{3}{4}$  oz.

Mark II differs from Mark III in not being waterproofed.

#### FUZE, DRILL, TIME AND PERCUSSION, No. 80.

The drill fuzes resemble, generally, the service fuzes which they represent, and in some cases burnt out service time and percussion fuzes are converted for the purpose. They are blacked all over with the exception of the flange of the body and a space on each of the composition rings, which are left bright. The lower time ring is fitted with a steel setting pin.

To facilitate identification the drill fuzes are stamped "DRILL" on the cap.

#### CLIP, CARTRIDGE, Q.F. 18-PR., MARK I.

The clip is made of brass, cross-shaped so as to form four arms, the ends of which are turned in to form clips to engage with the rim of the cartridge case. One arm is painted red, and is slightly longer than the others, the clip portion being differently shaped, so as to spring over the rim of the cartridge. The other three arms are sand blasted and black lacquered. It has a canvas loop for withdrawing the cartridges from the baskets or tubes in the ammunition boxes of the limbers and wagons.

The clip protects the cap of the percussion primer, and in the case of vehicles fitted with the brass tubes, also serves to hold the cartridge in the tube as follows:—

The cartridge (with its clip fixed) is inserted so that the red arm engages with the extended portion of the rim of the tube. When fully inserted, the clip is given part of a turn, thus bringing the end of the red arm inside the rim of the tube, and locking the cartridge in position.

#### CLIP, SAFETY, FUZE, TIME AND PERCUSSION, No. 80, MARK I.

The clip is of steel, horseshoe shaped, and fits round the No. 80 time and percussion fuze, retaining it at "safety." The clip has a slot in it to fit over the setting pin, and a tongue-piece fitting into the fixing slot; the ends also have projections which fit under the edge of the body of the fuze.

#### KEY, No. 17, FIXING NOS. 80 AND 83 FUZES.

The Mark II key is of steel, one end being shaped to fit over the fuze; the lower edge of the ring portion is bevelled to suit all Marks of No. 80 fuzes without covers, and is provided with a projection to fit the square notch in the flange of the fuze body. The upper edge of the ring is provided with a slot to fit over the projection on the cover when screwing in Mark IV., No. 80 fuzes with cover.

The Mark I key differs from the Mark II in the upper edge not being prepared for use with Mark IV fuzes with cover.

#### KEY, No. 18, SETTING NOS. 80 AND 83 FUZES.

The Mark I key is for use when the lower time ring is too stiff to set by hand. It is made of steel, and formed to engage with the pin projection of the lower time ring. It is provided with a loop of white line, 30 inches in length.

The Mark II key differs from the Mark I in the ring portion being of greater depth, thereby taking a better seating on the fuze.

Total length of key ... .. 6.17 inches.

#### KEY, No. 27, PRIMER 13 AND 18 PR.

This key is for use in inserting or removing the percussion primer in the cartridge. It is made of steel, and formed to engage with the two recesses in the head of the primer. It is also fitted with a white line lanyard.

Total length of key ... .. 13.1 inches.

" " lanyard ... .. 43 "

## LIST OF STORES.

### CARRIAGE.

Articles.	No.	Where carried.
Axe, pick .. .. .	1	Under trail.
Brush, breech screw .. .. .	1	In tool case, rear of shield.
Can, lubricating, No. 9 .. .. .	1	In wood block, rear of shield.
Carrier, No. 7, dial sight, No. 2.. .. .	1	On shield.
Case, keys, setting fuze† .. .. .	1	On shield.
Case, Mark III field clinometer† .. .. .	1	On shield.
Case, sight clinometer† .. .. .	1	On shield.
Case, spare parts† .. .. .	1	On shield.
Case, spare sight clinometer .. .. .	1†	On left tensile stay.
Case, telescope† .. .. .	1	On axletree.
Case, tools† .. .. .	1	On axletree.
Cleaner, piasaba, No. 7 .. .. .	1	In tubular trail.
Cleaner, wool, No. 1 .. .. .	1	In tubular trail.
Clinometer, field, Mark III .. .. .	1*	On rear of shield.
Clinometer, sight, Q.F., 13 and 18-pr. { (spare) .. .. .	1†	In case, on left tensile stay.
.. .. .	1	In case, on shield.
Cover, dial, sight, Q.F., 13 and 18-pr. .. .. .	1	On dial sight.
Cover, breech .. .. .	1	On gun. When not in use, strapped to front of shield.
Cover, muzzle, No. 1 .. .. .	1	On eccentric of brake gear.
Cover, eccentric, brake gear .. .. .	1	In leather case, on shield.
Drift, No. 12 .. .. .	1	In tool case, rear of shield.
Funnel, filling hydraulic buffer.. .. .	1	In leather case, on shield.
Gauge, striker, protrusion, No. 1 .. .. .	1	In tool case, rear of shield.
Hammer, claw, 20-oz. (or 24-oz.) .. .. .	1	In tool case, rear of shield.
Implements, ammunition—		
Keys, No. 18 (setting fuze) .. .. .	2	In case, on shield.
Key, removing jammed cartridges, Q.F., 13 and 18-pr. .. .. .	1†	In tool case, A sub-section.
Lanyard, firing, No. 15 .. .. .	1	In tool case, rear of shield.
Oil, Rangoon .. .. .	pts.	1

\* Per section.

† Components of carriage.

‡ Per battery.



## CARRIAGE—continued.

Articles.	No.	Where carried.
Ordnance, Q.F., 13 and 18-pr. :—		
Catch, retaining, breech screw (spare)	1	In leather case, on shield.
Pins, firing .. .. . (spare)	2	In leather case, on shield.
Springs { main .. .. . (spare)	2	In leather case, on shield.
{ safety catch .. .. . (spare)	2	In leather case, on shield.
{ trigger .. .. . (spare)	4	In leather case, on shield.
{ tripping piece .. .. . (spare)	1	In leather case, on shield.
Striker .. .. . (spare)	1	In leather case, on shield.
Pliers, flat nose .. .. . pr.	1	In tool case, rear of shield.
Posts, aiming .. .. . .. .	2	On front of shield.
Ropes, drag, light, G.S. .. .. . pr.	1	On front of shield.
Screw-driver, G.S., 4-in. .. .. .	1	In leather case, on shield.
Shovels, G.S. .. .. . .. .	1	Right tensile stay.
Sight, dial, No. 7. .. .. . .. .	1	On shield.
Spanner, McMahon, 15-in. (or adjustable 15-in.)	1*	In tool case, rear of shield.
Spanner, McMahon, 9-in. (or adjustable 11-in.)	1	In tool case, rear of shield.
Spanner, No. 244† .. .. . .. .	1	In tool case, rear of shield.
Spanner, hydraulic buffer, No. 122† .. .. .	1	In tool case, rear of shield.
Spanner, hydraulic buffer, No. 123† .. .. .	1	In tool case, rear of shield.
Spanner, hydraulic buffer, No. 129† .. .. .	1	In tool case, rear of shield.
Telescope, sighting No. 4 .. .. . .. .	1	In case, on axletree, left side.
Tool, withdrawing split pins† .. .. . .. .	1	In tool case, rear of shield.

\* Per section.

† Components of carriage.

## LIMBERS.

## (Carriage and Ammunition Wagon.)

Articles.	Carriage.	Wagon.	Where carried.	
Axes, { felling, curved helve .. .. .	1	—	On platform board.	
{ pick .. .. . .. .	—	1	Under limber.	
Bar, supporting draught pole, No. 3 (spare)	1	1*	On platform board.	
Blankets, G.S. .. .. . .. .	2	2	On top of limber box.	
Box, grease, 3-lb.† .. .. . .. .	1	1	Under platform board, "near" side.	
Breast piece .. .. . .. .	1	1	On platform board.	
Brushes, water, carriage .. .. . .. .	1	1	Under platform board, "near" side.	
Buckets, water, G.S., canvas .. .. .	12	6	In wire net receptacles.	
Cans, lubricating, No. 3, { for Rangoon oil†	1	1	} Under platform board, "off" side.	
{ for mineral oil†	1	1		
Carrier, ammunition, Q.F., 13 and 18-pr.	1	1	Under blankets.	
Cartridges, Q.F., 18-pr., shrapnel. .. .	24	38	In ammunition box.	
Clips, cartridge, Q.F., 18-pr. .. .. .	24	38	On cartridges.	
Cloths, sponge .. .. . .. .	5	5	Under tray, small stores.	
Collars, adjusting, 2nd class, "C," capped wheels .. .. . (spare)	1†	1*	Tray, small stores.	
Covers, rifle .. .. . .. .	2	2	On rifles, front of ammunition box.	
Files { smooth, { flat, 6-in. .. .. .	1	—	Tray, small stores, lower.	
	{ hand, safe edge, 6-in. .. .. .	1	—	Tray, small stores, lower.
	{ second cut, half round, 6-in. .. .	1	—	Tray, small stores, lower.
Grease, lubricating .. .. . lbs.	3	3	In grease box.	
Handle, file, small .. .. . .. .	1	—	Tray, small stores, lower.	
Hooks, bill .. .. . .. .	1	1	Under platform board, "off" side.	

\* Per sub-section.

† Components of limber.

‡ Lower tray.

## LIMBERS—continued.

## (Carriage and Ammunition Wagon.)

Articles.	Carriage.	Wagon.	Where carried.	
Implements, ammunition—				
Holder, cartridge. .. .. .	—	1§	Under tray, small stores.	
Keys, { No. 17 (fixing fuze) .. .. .	1†	1	Tray, small stores.	
{ No. 27 (primer) .. .. .	—	1*	Tray, small stores.	
{ No. 18 (setting fuze) .. .. .	2†	2	Tray, small stores.	
Key, split, flat, 1" × 4" .. .. . (spare)	1†	1*	Tray, small stores.	
Line Hambro .. .. . .. .	1	1	On platform board.	
Oil, mineral (for buffers) .. .. . pts.	2	2	In cans, lubricating.	
Oil, Rangoon .. .. . .. . pts.	1½	1½	In cans, lubricating.	
Pins, capsquare .. .. . (spare)	1	—	Tray, small stores, lower.	
Pins, keep, split, { 1/8 in. × 1 1/4 in. .. .. .	1	—	} Tray, small stores, upper (in rectangular tin box).	
	{ 3/8 in. × 1 1/4 in. .. .. .	1		—
	{ 1/2 in. × 1 1/4 in. .. .. . (spare)	3		—
	{ 1/2 in. × 1 in. .. .. .	2		—
	{ 1/2 in. × 2 1/2 in. .. .. .	1		—
Pins, split, { 1/2 in. × 1 1/4 in. .. .. .	9	—	} Tray, small stores, lower.	
	{ 3/8 in. × 1 in. .. .. .	1		—
	{ 1/4 in. × 5 in. .. .. .	1		—
Pins, lynch, 2nd class, "C," capped wheels (spare)	1†	1*	Tray, small stores.	
Pins, locking, shield pawl .. .. . (spare)	1	—	Tray, small stores, lower.	
Pins, draught, No. 3 .. .. . (spare)	1†	1*	Tray, small stores.	
Plugs, filling hole, hydraulic buffer, No. 12 (spare)	2	—	Tray, small stores, lower.	
Primers, percussion, Q.F., cartridges, No. 1 (in tin box) .. .. . (spare)	—	4	Tray, small stores.	
Rings, packing, hydraulic buffer (spare)	2	—	Tray, small stores, upper, each in round tin box.	
Ropes, drag, light, G.S. .. .. . pairs	—	1	On platform board.	
Screw-driver, G.S., 4-in. .. .. .	—	1	Tray, small stores.	
Screws, lubricating hole, boss-head, 5/16 in. × 1/4 in. .. .. . (spare)	6	—	Tray, small stores, upper (in rectangular box).	
Shovels, G.S. .. .. . .. .	{	2	On platform board.	
‡Spring, catch, limber and perch hooks (spare)	1	—	On side of box.	
Springs, disc, No. 62 .. .. . (spare)	1	—	Tray, small stores, upper.	
Springs, firing gear .. .. . (spare)	2	—	Tray, small stores, lower.	
Springs, shield pawl .. .. . (spare)	1	—	Tray, small stores, lower.	
Springs, sight clinometer (spiral) (spare)	1	—	Tray, small stores, upper (in rectangular box).	
Springs, traversing lever .. .. . (spare)	2	—	Tray, small stores, upper.	
Straps, supporting, { front .. .. . (spare)	2	2	} On platform board.	
	{ rear .. .. . (spare)	1		1
Straps, trace. .. .. . (spare)	2	2	On platform board.	
Stud, retaining stuffing box, hydraulic buffer .. .. . (spare)	1	—	Tray, small stores, upper (in rectangular tin box).	
Swingletree, Nos. 10A or 11 (spare)	1	1	On platform board.	
Syringe, Q.F., 13 and 18-pr. .. .. .	1§	—	Under lower tray, small stores.	
Tools, packing gland, { collar .. .. .	1	—	} Tray, small stores, upper (in round tin box).	
	{ plug .. .. .	1		—
Tools, withdrawing ring supporting packing, Q.F., 13 and 18-pr. .. .. .	2	—	Tray, small stores, upper.	

\* Per sub-section.

† When limbers are fitted with new pattern hooks.

‡ Lower tray.

§ Per section.

LIMBERS—*continued.*  
(Carriage and Ammunition Wagon.)

Articles.	Carriage.	Wagon.	Where carried.
Traces, saddlery .. .. . pairs	1	1	On platform board.
Tugs, trace .. .. . (spare)	2	2	On platform board.
Washers, drag, 2nd class, "C," capped wheels .. .. . (spare)	1	1*	Under footboard, "near" side.
Washers, packing, hydraulic buffer sets (spare)	2	—	Tray, small stores, upper (in round tin box).

\* Per sub-section.

AMMUNITION WAGONS.

Articles.	No.	Where carried.
Apparatus, adjusting, running out springs, Q.F., 18-pr. .. .. .	1††	On platform board.
Blankets, G.S. .. .. .	2	On top of ammunition box.
Box, lamp, siege, to hold 2 .. .. .	1	On footboard.
Boxes, grease, 14-lb.    .. .. .	2	Under platform board.
Bush, testing sighting, 3-3-in. .. .. .	1**	In tray, small stores, A sub-section.
Cartridges, Q.F., 18-pr., shrapnel .. .. .	38	In ammunition box.
Case, saw, hand .. .. .	1	Lid of ammunition box.
§Catches, limber and perch hooks (spare)	1*	In tray, small stores.
Clips, cartridge, Q.F., 18-pr. .. .. .	38	On cartridges.
Covers, apparatus, adjusting, running out springs .. .. .	1††	On platform board.
Grease, lubricating .. .. . lb.	28	In boxes.
Handspike, common, 6 feet .. .. .	1	Under perch.
Implements, ammunition—		
Keys, No. 18 (setting fuze) .. .. .	2	In tray, small stores.
Indicator fuze, Q.F., 18-pr. .. .. .	1	On top of ammunition box.
Kettles, camp, oval, 12-quarts .. .. .	—	Under wagon, as required.
Lamps, siege .. .. .	2	In box.
Lashing, tarred, 1 in. x { 20 feet .. .. .	1†	Under wagon, as required.
{ 10 feet .. .. .	1†	Under wagon, as required.
Line, white, 1 lb. skeins .. .. .	1	Under tray, small stores.
Nut, actuating screw, brake gear (spare)	1*	In tray, small stores.
Ordnance, Q.F., 13 and 18-pr.—		
Bush, firing hole .. .. . (spare)	1*	In tray, small stores.
Pole, draught, No. 18 .. .. . (spare)	1†	Under perch.
Rope, picketing, 66 feet .. .. .	1	On platform board.
Saw, hand, 26-in. .. .. .	1	In case, saw, hand.
Spanner, No. 93 .. .. .	1†	In case, side of ammunition box.
§Spindle, catch, limber and perch hooks (spare)	1*	In tray, small stores.
§Spring, catch, limber and perch hooks (spare)	1	In tray, small stores.
Spring, spiral (clock type), range gear, Q.F., 13 and 18-pr. .. .. . (spare)	1**	In tray, small stores.
Valise, horse shoe .. .. .	1¶	Front of ammunition box.
Valises, tools (shoeing, wheelers, or saddlers) .. .. .	—¶	Front of ammunition box.

\* Per section.

† Per sub-section.

|| Components of wagon.

\*\* 1 per battery.

† For each ammunition wagon carrying a spare No. 18 pole.

§ When limbers are fitted with new pattern hooks.

¶ See footnote ¶, page 46.

†† Per battery, carried in "A" sub-section.

Note.—The spare pole is lashed in position as follows:—

Place the pole in position under the perch with the jointed parts to the rear; care must be taken that the ends do not project to the rear so as to get in the way of the wagon body shield, and prevent it being lowered.

Securely lash the pole by one of the lashings to the front end of the perch. This lashing should be passed round the pole through the pole tug. (The pole tug should be secured in the front tug hole of the pole.) With the second lashing, make fast one end to the iron loop supporting the pole, take a complete turn round each half of the pole and the loop separately, then pass the lashing twice round the ends of the pole and the loop, to prevent the pole working to the rear, and make fast.

WAGON, TELEPHONE.

Articles.	No.	Where carried.
Apron, basil, brown .. .. .	1	Limber box, compartment C 1.
Axe, felling, curved helve .. .. .	1	Under footplate of limber.
Axe, pick { Head, 4½-lb. .. .. .	1	} Near side, limber.
{ Helve, 36-inch, ferruled... .. .	1	
Bar, carrying drum, wagon, telephone... .. .	1	Top of limber box.
Bar, supporting draught pole, No. 3 (spare)	1	Platform board, limber.
Blocks, brake, field and transport (spare)	2	Limber box, compartment C 2.
Bolts, link, chain, endless, wagon, telephone .. .. . (spare)	2*	Limber box, compartment D.
Bracket, pawl, winding gear, No. 198A wheel .. .. . (spare)	1	Limber box, compartment D.
Brush, water, carriage .. .. .	1	Near side, limber.
Buckets, water, G.S., canvas .. .. .	2	Platform board, limber.
Cable, electric, D 1 .. .. . miles	½	On reels, cable, No. 2.
Cable, electric, D 3 .. .. . miles	4	On drums.
Can, oil, lubricating, 1-pint .. .. .	1	Limber box, compartment E.
Catch, drum spindle bearing, wagon, cable and telephone .. .. . (spare)	1*	Limber box, compartment D.
Cells, electric, { .. .. .	12	} Limber box, compartment A.
{ (spare) in box... .. .	12	
Clip, strap, winding gear, wagon, telephone .. .. . (spare)	1*	Limber box, compartment D.
Cloth, emery, No. F .. .. . sheets	4	Limber box, compartment C 2.
Collar, adjusting, 2nd Class "C" capped wheels .. .. . (spare)	1	Limber box, compartment B 3.
Cordage, spun yarn, { 1 thread... lbs. .. .. .	20	} Limber box, compartment D.
{ 3 thread... lbs. .. .. .	5	
Covers, short rifle .. .. .	2	Front of " " " "
Galvanometer, detector—		
Q and I .. .. .	1	} Limber box, compartment A.
Case .. .. .	1	

\* Packed in small wooden box, provided locally.



(As to prices in brackets, see top of page 2.)

- GUNS.** Handbooks for. (And see GUNS. Drill for):—
- 60-pr. B.L. Land Service. 1913. 1s. 6d. (1s. 3d.)
  - 18-pr. Q.F. Land Service. 1913. (Reprinted, with Amendments, 1914). 1s. (11d.)
  - 15-pr. B.L. Marks II. to IV., and Carriages, Marks II.\* and IV., and Wagon, and Limber, Mark IV. Field Batteries. 1914. Provisional. 1s. (10d.)
  - 15-pr. B.L.C. Marks I., II., II.\*, and IV. with Mark I. Carriage, and Marks I., Ia, Ib, and Ic Limbers and Wagons. Land Service. 1912. 1s. (10d.)
  - 15-pr. Q.F. Land Service. 1914. 1s. 6d. (1s. 2d.)
  - 13-pr. Q.F. Land Service. 1913. (Reprinted, with Amendments, 1914). 1s. 3d. (1s. 1d.)
  - 12-pr. B.L. of 6-cwt. Marks I. to IV. and IVa, and Carriages Marks I.\*, I.\*\*, and II. Horse Artillery. 1905. 1s. (11d.)
  - 10-pr. Jointed B.L. Mule Equipment. 1914. 1s. 6d. (1s. 2d.)
  - 9-45-inch B.L. Howitzer. 1906. 9d. (7d.)
  - 9-2-inch B.L. Mark IX., "C" Mark IX., and Marks X., Xv., and X.\* Land Service. 1912. 1s. (11d.)
  - 8-inch R.M.L. Howitzer of 70 cwt. Movable Armament and Armament of Works. Land Service. 1901. 2s. (1s. 6d.)
  - 6-inch B.L. and B.L.C. Guns, Mountings, &c. 1904. 1s. 6d. (1s. 4d.)
  - 6-inch B.L. Marks VII. and VIIv. Land Service. 1911. 9d. (8d.)
  - 6-inch B.L. 30-cwt. Howitzer. Marks I. and I\*. 1915. 1s. 6d.
  - 6-inch Q.F. Land Service. 1903. 1s. (10d.)
  - 6-inch "B" Q.F. Land Service. 1911. 1s. (10d.)
  - 5-4-inch B.L. Howitzer. Mark I. 1902. 1s. 6d. (1s. 2d.)
  - 5-inch B.L. Marks I.—V. 1904. 9d. (9d.)
  - 5-inch B.L. Marks IV.—V. Land Service. 1903. 1s. 6d. (1s. 2d.)
  - 5-inch B.L. Howitzer. 1909. 9d. (9d.)
  - 4-7-inch Q.F. Fixed Armaments. Land Service. 1904. 1s. (11d.) (Under revision)
  - 4-7-inch Q.F.B. on Travelling Carriages. Land Service. 1910. (Reprinted, with Amendments, 1914). 9d. (8d.)
  - 4-5-inch Q.F. Howitzer. Land Service. 1914. 1s. 3d. (1s. 1d.)
  - 2-95-inch Q.F. Mule Equipment and Man Transport Equipment. 1914. 2s. (1s. 6d.)
  - 303-inch Vickers Machine (Magazine Rifle Chamber), on Tripod Mounting, Mark IV. 1914. 6d. (6d.)
  - 303-inch Nordenfeli 3-barrel and Gardner 2-barrel converted from 0-4-inch and 0-45-inch M.H. Chamber, Magazine Rifle Chamber, on Carriages. 1900. 9d. (8d.)

**HISTORICAL RECORDS OF THE BRITISH ARMY:—**

- Horse Guards. 5s. (3s. 7d.)
- Dragoon Guards, 3rd, 4th, 5th, 6th, and 7th. Each 4s. (3s.)
- Dragoons, 1st, 3rd, 7th, 14th, and 16th. Each 4s. (3s.)
- Ditto. 12th and 18th. Each 3s. (2s. 3d.)
- Marine Corps. 3s (2s. 2d.)
- Foot, 2nd, 6th, 8th, 10th, 11th, 13th, 16th, 17th, 18th, 19th, 20th, 21st, 22nd, 34th, 36th, 39th, 46th, 53rd, 67th, 71st, 72nd, 73rd, 74th, 86th, 87th, and 92nd. Each 4s. (3s.)
- Do. 14th, 56th, 61st, 70th, and 88th. Each 3s. (2s. 3d.)

**HISTORIES, SHORT, OF THE TERRITORIAL REGIMENTS OF THE BRITISH ARMY.** 67 numbers, each 1d. (1d.); In one volume, 5s. (3s. 9d.)

- Ditto. The Scots Guards. 1d. (1d.)
  - Ditto. The 6th (Inniskilling) Dragoons. 1d. (1d.)
  - Ditto. Revised Editions. 1d. (1d.) each:—
- |  |   |
|--|---|
| <ul style="list-style-type: none"> <li>Alexandra, Princess of Wales's Own (Yorkshire Regiment).</li> <li>The Bedfordshire Regiment.</li> <li>The Black Watch (Royal Highlanders).</li> <li>The Cameronians (Scottish Rifles).</li> <li>The Cheshire Regiment.</li> <li>The Duke of Wellington's West Riding Regiment.</li> <li>The Durham Light Infantry.</li> <li>The East Lancashire Regiment.</li> <li>The East Surrey Regiment.</li> <li>The Hampshire Regiment.</li> <li>The Highland Light Infantry.</li> <li>The King's Own Yorkshire Light Infantry.</li> <li>The Lancashire Fusiliers.</li> <li>The Loyal North Lancashire Regiment.</li> </ul> | <ul style="list-style-type: none"> <li>The Northamptonshire Regiment.</li> <li>The Oxfordshire and Buckinghamshire Light Infantry.</li> <li>The Prince Albert's (Somersetshire Light Infantry).</li> <li>The Prince of Wales's Leinster Regiment (Royal Canadians).</li> <li>The Prince of Wales's Volunteers (South Lancashire Regiment).</li> <li>The Princess Charlotte of Wales's (The Royal Berkshire Regiment).</li> <li>The Princess Louise's Argyll and Sutherland Highlanders.</li> <li>The Royal Inniskilling Fusiliers.</li> <li>The Royal Sussex Regiment.</li> <li>The Royal Warwickshire Regiment.</li> <li>The Royal Welsh Fusiliers.</li> <li>The Suffolk Regiment.</li> <li>The Welsh Regiment.</li> </ul> |
|--|---|

**HOSPITALS. MILITARY FAMILIES'. Nursing Staff Regulations. Dec. 1909. 1d. (1d.)**

(As to prices in brackets, see top of page 2.)

- HOSTILITIES WITHOUT DECLARATION OF WAR FROM 1700 TO 1870.** 2s. (1s. 7d.).
- HYGIENE. ELEMENTARY MILITARY.** Manual of. 1912. 6d. (6d.)
- INDIAN EMPIRE. OUR.** A short review and some Hints for the use of Soldiers proceeding to India. 6d. (6d.)
- INFANTRY TRAINING.** (4-company organization.) 1914. 6d. (6d.)
- INSTITUTES.** Garrison and Regimental. Rules for the Management of. 1912. 1d. (1d.)
- INTELLIGENCE DUTIES IN THE FIELD.** Regns. for. 1904. 2d. (2d.)
- ITALIAN CAVALRY TRAINING REGULATIONS.** 1911. Training for Marches, Tactics of Minor Units, and Training of Patrols. Translated. 4d. (3d.)
- JAMAICA.** Standing Orders. 1912. 1s. (9d.)
- JERSEY. ROYAL MILITIA OF THE ISLAND OF.** Regulations. 1914. With the Jersey Militia Law, 1905. 1s. 3d. (11d.)
- KING'S REGULATIONS AND ORDERS FOR THE ARMY.** 1912. (Reprinted, with Amendments published in Army Orders up to Aug. 1, 1914.) 1s. (1s.)
- KIT PLATES:—**
- Artillery. Royal—
1. Horse and field. Kit in Barrack Room. 1912. 2d. (2d.)
  2. Ditto. Kit laid out for Inspection. 1908. 2d. (2d.)
  6. Garrison. Kit laid out for Inspection. 1909. 2d. (2d.)
  10. Ditto. Kit in Barrack Room. 1909. 2d. (2d.)
- Cavalry. 1891. 1d. (1d.)
- Engineers. Royal—
1. Dismounted. Detail of Shelf and Bedding, with Marching Order ready to put on. Detail of Shelf and Bedding, with Drill Order ready to put on. 1914. 1d. (1d.)
  2. Dismounted. Full Kit laid out for Inspection in Barrack Room. 1914. 1d. (1d.)
  4. Mounted N.C.O. or Driver and Field Troop Sapper. Full Kit laid out for Inspection in Barrack Room. 1910. 1d. (1d.)
  5. Mounted. Detail of Shelf and Bedding. 1910. 1d. (1d.)
  6. Driver, with pair of Horses. Field Kit laid out for Inspection on Parade, including Articles carried in Valise on Baggage Wagon. 1899. 1d. (1d.)
- Infantry—
1. Kit in Barrack Room. 1905. 2d. (2d.)
  2. Kit laid out for Inspection. 1905. 2d. (2d.)
- Highland. 1884. 1d. (1d.)
- Medical Corps. Royal Army. Kit in Barrack Room. 1912. 2d. (2d.)
- Ordnance Corps. Army. For Guidance at Marching Order and Kit Inspections. 2d. (2d.)
- LARGE FORMATIONS.** The Operations of. (Conduite des Grandes Unités). Translated from the Field Service Regulations of the French Army, dated Oct. 28, 1913. 6d. (5d.)
- LAW.** Military. Manual of. 1914. 2s. (1s. 9d.)
- LAW FOR THE RESERVE FORCES AND MILITIA.** Manual of. 1886. 1s. 6d. (1s. 2d.)
- MACHINE-GUN.** Tests of Elementary Training. 1d. (1d.)
- MACHINE GUNS AND SMALL ARMS, .303-inch.** Nomenclature of Parts, Stripping, Assembling, Action, Jams, Missfires, Failures, and Inspection of. Revised Edition. 1913. 3d. (3d.); Amendments, No. 1. 1d. (1d.)
- MAGAZINES AND CARE OF WAR MATÉRIEL.** Regulations for. 1913. 9d. (9d.); Amendments, July 1914. 1d. (1d.)
- MAP READING AND FIELD SKETCHING.** Manual. 1912. (Reprinted, with Additions, 1914.) 1s. (11d.) (And see Schools, Army.)
- MECHANISM AS APPLIED TO ARTILLERY.** Notes on. Second Edition, 1902. 1s. (11d.)
- MEDICAL CORPS.** Royal Army (And see Territorial Force):—
- Admission to. Regulations for. Jan. 1912. 1d. (1d.)
- Standing Orders. 1914. 1s. (10d.)
- Training. 1911. 9d. (9d.)
- MEDICAL DEPARTMENT.** Army. Index to Appendices of Reports from 1859 to 1896. 3d. (3d.)

(As to prices in brackets, see top of page 2.)

- MEDICAL SERVICE.** Army. Regulations. 1906. (Reprinted, with Amendments up to Sept. 30, 1914.) 4d. (5d.)
- MEDICAL SERVICE.** Strategical and Tactical Employment of the, as carried out in an Army Corps; with a series of Problems. Translated from the Austrian. 4s. 6d. (3s. 4d.)
- MEDICAL SERVICES.** Army. Advisory Board for. The Treatment of Venereal Disease and Scabies. First Report. 1904. 1s. 6d. (1s. 3d.); Second Report. 1905. 2s. (1s. 6d.); Third Report. 1905. 1s. (10d.); Final Report. 1906. 6d. (5d.)
- MEDICAL SERVICES OF FOREIGN ARMIES.** Handbook of.
- |                                      |  |
|--------------------------------------|--|
| Part I. FRANCE ... .. 6d. (5d.)      | Part IV. RUSSIA ... .. 6d. (5d.)                   |
| Part II. GERMANY ... .. 6d. (5d.)    | Part V. ITALY ... .. 6d. (5d.)                     |
| Part III. AUSTRIA-HUNGARY. 6d. (6d.) | Part VI. THE NETHERLANDS AND BELGIUM ... 6d. (5d.) |
- MEKOMETER** Handbook. 1911. 6d. (6d.)
- MILITARY LANDS ACTS, 1892 to 1903.** Byelaws. (See Artillery and Rifle Ranges Act, &c.)
- MUSKETRY REGULATIONS:—**
- Part I. 1909. (Reprinted, with Amendments, 1914.) 6d. (7d.)
- Part II. Rifle Ranges and Musketry Appliances. 1910. (Reprinted, with Amendments to Oct. 31, 1914.) 4d. (4d.)
- NIGHT OPERATIONS.** Elementary Training in. 1911. 1d. (1d.)
- NUMBER OF TROOPS TO THE YARD** in the Principal Battles since 1850. Memo. on. With opinions of Modern Authorities on limits of extension at the present day. 1884. 9d. (7d.)
- NURSING IN THE ARMY.** Queen Alexandra's Imperial Military Nursing Service. Reprinted from "The British Medical Journal." 1905. 1d. (1d.)
- NURSING SERVICE.** Queen Alexandra's Imperial Military. Regulations for Admission to the. 1914. 1d. (1d.)
- OFFICERS TRAINING CORPS:—**
- Regulations. 1912. 2d. (2d.) (Under revision)
- Ditto. (Inns of Court). 1d. (1d.)
- Special A.O., March 16, 1908. 1d. (1d.)
- Junior Division. Instructions for the Annual Camps. 1913. 2d. (2d.)
- OPERATION ORDERS.** A Technical Study, by HANS VON KIESLING. Translated from the German. 1s. 6d. (1s. 3d.)
- OPTICAL MANUAL** or Handbook of Instructions for the guidance of Surgeons. Third Edition. 1885. 1s. 6d. (1s. 3d.)
- OPTICS.** Notes on. 6d. (5d.)
- ORANGE FREE STATE.** Topographical Survey of the, 1905-1911. Report on the 10s. (7s.)
- ORDNANCE COLLEGE** (and see Artillery College):—
- Advanced Classes (up to the 33rd). Reports on. Each 1s. (9d.)
- Ditto, 34th. 6d. (5d.)
- Dynamics. Notes on. Second Edition. 3s. (2s. 5d.)
- Officers' Mess (Royal Artillery) Management and First Principles of Book-keeping. 3d. (3d.)
- Ordnance Courses. Reports on. Each 1s. (9d.)
- Regulations. 1907. 2d. (2d.)
- ORDNANCE CORPS.** Army. Standing Orders. 1912. 6d. (6d.) (Under revision)
- ORDNANCE MANUAL (WAR).** 1914. 6d. (5d.)
- ORDNANCE SERVICE.** Treatise on. Seventh Edition. 1908. With volume of plates. 7s. 6d. (5s. 6d.) Amendments. June 1909, Dec. 1910, Dec. 1912; April 1914. Each 1d. (1d.); Do. Dec. 1909, Dec. 1911. Each 2d. (2d.)
- ORDNANCE SERVICES. ARMY.** Regulations:—
- Part I. 1912. (Reprinted, with Amendments published in Army Orders up to Oct. 1, 1914.) 6d. (6d.)
- Part II. 1914. Instructions for Laboratories and Laboratory Operations, Examination of Explosives and Ordnance. 1s. (11d.)
- PATHOLOGICAL SPECIMENS** in the Museum of the Army Medical Department, Netley. Descriptive Catalogue of. Third Edition. Vol. I. By Sir W. Aitken, M.D. 1892. 5s. (3s. 8d.)

(As to prices in brackets, see top of page 2.)

- PAY DUTIES** of Officers Commanding Squadrons, Batteries, Companies, &c. Instructions. 1914. 1d. (1d.) (Under revision)
- PHYSICAL TRAINING.** Manual of. (Reprint 1908 with Amendments published in Army Orders to Dec. 1, 1914). 9d. (9d.)
- PLACE-NAMES OCCURRING ON FOREIGN MAPS.** Rules for the Transliteration of. 1906. 1s. (9d.)
- PORTABLE SUB-TARGET** (Mark I.), and How to Use it. 1911. (Reprinted with Amendments, 1914.) 1d. (1d.)
- POSTAL SERVICES. ARMY. WAR.** Manual of. 1913. 3d. (3d.)
- PROJECTION, &c.** Linear Perspective. A Text Book for the use of the R.M. Academy. Part I.—Text. Part II.—Plates. 1904. 6s. (4s. 5d.)
- PUBLICATIONS (RECENT) OF MILITARY INTEREST.** List of Quarterly. Nos. 1 to 8. 2d. (2d.) each. Nos. 9 to 17. 4d. (4d.) each. [Continued by THE ARMY REVIEW.]
- RAILWAY DISTANCES.** Ireland. Handbook of. Third Edition. 1884. 7s. 6d. (5s. 3d.)
- RAILWAY MANUAL (WAR).** 1911. (Reprinted, with Amendments, 1914). 6d. (5d.)
- RAILWAYS. MILITARY. RECONNAISSANCE AND SURVEY OF.** Notes on, for Officers of R.E. Railway Companies. 1910. 2s. 3d. (1s. 8d.)
- RANGE-FINDER** Handbooks:—  
Infantry No. 1 (Marindin). 1913. 3d. (3d.)  
Infantry No. 2 (Barr and Stroud). 31.5-inches base. 1913. 8d. (8d.)  
Watkin. Regulations for Instruction in, and practice with. 1882. 1s. (9d.)
- RANGE-FINDING. COAST DEFENCE.** Manual of. Part I. 9d. (8d.)  
Ditto. Amendments, June 30, 1914. 1d. (1d.)
- RANGES. MINIATURE CARTRIDGE.** (Reprinted from THE ARMY REVIEW, Jan. 1914). 3d. (3d.)
- RECRUITING FOR THE REGULAR ARMY AND THE SPECIAL RESERVE.** Regulations. 1912. (Reprinted, with Amendments to Aug. 31, 1914). 3d. (3d.)
- REMOUNT MANUAL (WAR).** 1913. 2d. (2d.)
- REMOUNT REGULATIONS.** 1913. 3d. (3d.)
- REQUISITIONING OF SUPPLIES, TRANSPORT, STORES, ANIMALS, LABOUR, &c., IN THE FIELD.** Instructions for the. 1907. 1d. (1d.)
- RESERVE** (and see Motor Reserve; Special Reserve):—  
Army Reserve. Class I. Regulations. 1911. 1d. (1d.)  
Ditto. Amendments, June 1913. 1d. (1d.)  
National Reserve. Regulations. 1913. 1d. (1d.)
- RIFLE RANGES.** Care and Construction of. Instructions for. 1908. 3d. (3d.)
- RIFLE RANGES, TRAINING GROUND, AND MUSKETRY CAMP, PENALLY.** (Western Coast Defences.) Standing Orders. 1910. 2d. (2d.)
- RIFLES, &c.** Cleaning of. Notes on the. 1911. 2s. for 6d. (7d.)
- RIFLES, SHORT AND CHARGER-LOADING, MAGAZINE, LEENFIELD.** Handbook for Serjeant-Instructors of Special Reserve, Officers Training Corps, and Territorial Force in regard to the Care, Inspection, &c., of. 3d. (3d.)
- RUSSIAN MILITARY AND NAVAL TERMS.** Dictionary of. 1906. 3s. 6d. (2s. 6d.)
- RUSSO-JAPANESE WAR:—**  
Medical and Sanitary Reports from Officers attached to the Japanese and Russian Forces in the Field. 1908. 5s. (3s. 10d.)  
Official History. Part I. Causes of the War. Opening Events up to and including the Battle of the Ya-lu. Second Edition. 1909. 1s. 6d. (1s. 3d.); Part II. From the Battle of the Ya-lu to Liao-yang, exclusive. 1908. 5s. (3s. 8d.); Part III. The Siege of Port Arthur. 1909. 4s. 6d. (3s. 4d.); Part IV. Liao-yang. 1910. 4s. (3s.); Part V. Sha Ho. 1911. 4s. 6d. (3s. 5d.)  
Official History (Naval and Military). Vol. I. To Aug. 24, 1904. With case of Maps. 1910. 15s. (10s. 7d.); Vol. II. Liao-yang, the Sha Ho, Port Arthur. With case of Maps. 1912. 15s. (10s. 10d.)  
Reports from British Officers attached to the Japanese and Russian Forces in the Field. In three Vols., with two cases of Maps (not sold separately). 21s. (15s.)
- SALISBURY PLAIN. SOUTHERN COMMAND.** Standing Orders applicable to all Troops Encamped on Salisbury Plain, and applicable generally to Troops Quartered at Bulford and Tidworth. 1913. 3d. (3d.)
- "SAM-BROWNE" BELT, SCABBARD, AND SWORD KNOT.** Specification and Drawings. 1899. 1d. (1d.)

(As to prices in brackets, see top of page 2.)

- SCHOOLS. Army:—**  
Annual Reports on. 1911-12; 1912-13. Each 1s. (9d.)  
Map Reading. Notes on. 1915. 3d. (3d.)  
(And see Map Reading and Field Sketching.)  
Military and other Terms, and Words which Occur in Orders. Lists of. 1914. 2d. (2d.)  
Physiology. Elementary. Handbook. 1901. 1d. (1d.)  
Regulations. 1911. 4d. (4d.)  
School Hygiene. Handbook of. For Teachers. 6d. (6d.)  
Singing in. Regns. for Teaching. 1911. 1d. (1d.)  
Standing Orders for Inspectors, Examiners, Teachers. 1910. 6d. (5d.)  
Type Exercises of Extracts from Regimental Orders for use of Candidates for Third-class Certificates of Education. 1912. 3d. (3d.)
- SCOUTS.** Training and Use of. Lecture by Col. F. C. Carter. 1905. 2d. (2d.)
- SCREWS.** Standard Leading. Provision of, for Screw-cutting Lathes. Report of Committee. 1905. 1s. (10d.)
- SEVASTOPOL.** Siege of. 1854-55. 3 vols., with Case of Maps and Plans. Half Mor., £5 4s. Cloth, £4 4s.  
Or separately:—Vol. I. Engineer Operations. £1 6s.; Vol. II. Ditto. With Case of Maps and Plans. £2 10s.; Vol. III. Artillery Operations. 10s.
- SEWAGE.** Practical Treatment of. The latest development of. 1903. 6d. (5d.)
- SHOEBURYNNESS GARRISON.** Standing Orders. 1913. 1s. 6d. (1s. 1d.)
- SIEGE OPERATIONS** in the Campaign against France, 1870-71. (Von Tiedemann.) Translated. 4s. 6d. (3s. 3d.)
- SIGNALLING.** Training Manual. 1907. (Reprinted, with Amendments to May 1, 1911). (Out of print); Amendments. Nov. 1912, May 1913, April and Aug. 1914 (in one). Each 1d. (1d.); Appendix IV. Despatch Riding. 1d. (1d.)
- SIGNALLING.** Training Manual. Part II. For the use of the Divisional Signal Companies and Intercommunication Personnel of Units in Divisions, other than 1st to 8th Divisions, of the Intercommunication Personnel of Units of the Territorial Force other than Signal Units and R.G.A. Coast Defence Companies, and of Signallers of King Edward's Horse. 1914. 6d. (5d.)  
Ditto. Appendix I. Telephone Cable Drill. Artillery. 1d. (1d.)  
Ditto. Appendix II. Telegraph Cable Drill. 2d. (2d.)
- SIGNALLING DISC.** Directions for Use. 1911. 1d. (1d.)
- SIGNAL SERVICE. THE ARMY.** 1d. (1d.)
- SIGNAL SERVICE. ARMY.** Manual of—WAR. Provisional. 1914. 2d. (2d.)
- SMALL ARMS.** Text Book. 1909. With Tables. 2s. 6d. (2s. 1d.)
- SMALL WARS.** Their Principles and Practice. Third Edition. 1906. (Reprinted, 1909.) 4s. (3s.)
- SOMALILAND:—**  
Military Report on. 1907. Vol. I. Geographical, Descriptive, and Historical. 2s. (1s. 7d.)  
Operations in, 1901-04. Official History. Vol. I. 3s. (2s. 4d.); Vol. II. 4s. (3s.)
- SOUTH AFRICAN WAR, 1899-1902:—**  
Medical Arrangements. 7s. 6d. (5s. 6d.)  
Medical History. An Epidemiological Essay. (Reprinted from "The Journal of the Royal Army Medical Corps.") 3s. 9d. (2s. 9d.)  
Railways. 4s. (3s.)  
Surgical Cases Noted. 7s. 6d. (5s. 6d.)  
Telegraph Operations. 10s. (7s. 1d.)  
Voluntary Organizations in aid of the Sick and Wounded. Report of the Central British Red Cross Committee on. 1902. 3s. (2s. 5d.)
- SPECIAL RESERVE:—**  
Commission in the Special Reserve of Officers. Short guide to obtaining a; &c. 1d. (1d.)  
Regulations for Officers of the Special Reserve of Officers, and for the Special Reserve. 1911. 4d. (5d.)  
Scheme for the Provision, Organization, and Training of the Special Reserve required to supplement the Regular Army, and the Application of the Scheme to the existing Militia. (Special A.O., Dec. 23, 1907.) 2d. (2d.)  
Scheme for the Provision, Organization, and Training of that portion which will be drawn from the Territorial Force to supplement the Regular Army on Mobilization being ordered. (Special A.O., Nov. 20, 1908.) 2d. (2d.)

(As to prices in brackets, see top of page 2.)

- STAFF COLLEGE** Regulations (Camberley). 1905. Reprinted with Amendments up to Nov. 30, 1910. 1d. (1d.)
- STAFF.** General. Duties of. (Von Schellendorff.) Fourth Edition. 1905. (Out of print)
- STATIONS OF UNITS OF THE REGULAR FORCES, MILITIA, SPECIAL RESERVE, AND TERRITORIAL FORCE.** Quarterly up to No. 45, July 1914. Each 2d. (2d.) (Publication suspended)
- STATUTES** relating to the War Office and to the Army. 1880. 5s. (3s. 9d.)
- STATUTORY POWERS** of the Secretary of State, Ordnance Branch. 1879. 5s. (3s. 9d.)
- STEAM ENGINES AND BOILERS, AND GAS AND OIL ENGINES.** Management of. Notes and Memoranda. 1911. 1d. (1d.)
- SUDAN ALMANAC.** 1915. Compiled in the Intelligence Department, Cairo. 1s. (9d.)
- SUDAN. THE BRITISH FORCE IN THE.** Standing Orders. 1914. 9d. (7d.)
- SUDAN.** The Anglo-Egyptian. A Compendium prepared by Officers of the Sudan Government:—  
Vol. I. Geographical, Descriptive, and Historical (with Eighty-two Illustrations). 10s. (7s. 4d.)  
Vol. II. Routes. 7s. 6d. (5s. 5d.) (Not containing Chapter VII, Supplement (A).)  
Ditto. In Separate Chapters. 1s. (10d.) each:—  
I. and II. Nil. III. North-Eastern Sudan. IV. Eastern Sudan. V. Central Sudan. VI. South-Eastern Sudan. VII. Bahr-el-Ghazal. VIII. Kordofan IX. North-Western Sudan.  
Ditto. Chapter VII. Supplement (A). Bahr-el-Ghazal. Additional Routes. 1s. (10d.)
- SUDAN CAMPAIGN.** History of the. Two parts, and Maps. 1890. 15s. (10s. 11d.)
- SUPPLY MANUAL (WAR).** 1909. 6d. (6d.)
- SUPPLY. REORGANIZED SYSTEMS OF,** and of Ammunition Supply of the Expeditionary Force in War, consequent on the introduction of Mechanical Transport. Memorandum explaining the. Feb. 1912. 1d. (1d.)
- SUPPLY, TRANSPORT, AND BARRACK SERVICES.** Regulations. 1908. 9d. (8d.) (Under revision)
- SURVEYING.** Topographical and Geographical. Text Book of. Second Edition. 1913. 7s. 6d. (5s. 6d.)  
Ditto. 1905. Appendix XI. Tables for the Projection of Graticules for squares of 1° side on scale of 1: 250,000, and for squares of ½° side on scale of 1: 125,000; with other Tables used in Projection Maps. 4d. (4d.)  
Ditto. 1905. Appendix XII. Tables for the Projection of Graticules for maps on the scale of 1: 1,000,000. 1910. 2d. (2d.)
- TACTICAL RIDES AND TOURS ON THE GROUND.** The Preparation and Conduct of. Translated from the German. 1s. 3d. (1s. 1d.)
- TELEGRAPHY AND TELEPHONY.** Army. Instruction in:—  
Vol. I. Instruments. (Reprinted, with Corrections, 1914). 1s. 6d. (1s. 4d.)  
Vol. II. Lines. 1909. (Reprinted, with Corrections, 1914). 1s. (11d.)
- TELESCOPIC SIGHTS.** Handbook. Land Service. 1904. 4d. (4d.)
- TERRITORIAL FORCE** (and see Equipment; Establishments):—  
Cadet Units in the British Isles. Regulations governing the Formation, Organization and Administration of. 1914. (Reprinted, with Amendments in Army Orders to Dec. 1, 1914). 1d. (1d.)  
Field Kits. Officers and Men. 1d. (1d.)  
Hospitals, General, of the. Regulations for. 1912. 2d. (3d.)  
Medical Corps. Royal Army. Syllabus of Training. 1914. 1d. (1d.)  
Mobilization of a Territorial Infantry Battalion. (Reprinted from THE ARMY REVIEW, July 1913). 3d. (3d.)  
Nursing Service. Standing Orders. 1912. (Reprinted, with Amendments, 1914). 1d. (1d.)  
Regulations for the (including the Territorial Force Reserve), and for County Associations. 1912. (Reprinted, with Amendments published in Army Orders to Dec. 1, 1914). 6d. (7d.)

(As to prices in brackets, see top of page 2.)

- Territorial Force—continued.**  
Voluntary Aid:—  
Scheme for the Organization of, in England and Wales. Dec. 1910. (Out of print)  
Ditto. Ditto. Amendments. 1d. (1d.)  
Ditto, in Scotland. Oct. 1911. 2d. (2d.)  
Ditto. Ditto. Amendments. 1d. (1d.)  
Training. (Extracts from "Medical Corps. Royal Army. Training. 1911"). 6d. (7d.)
- TRACTOR TRIALS** held by the Experimental Sub-Committee of the Mechanical Transport Committee at Aldershot, Sept. and Oct. 1903. Report on. 6d. (5d.)
- TRAINING AND MANŒUVRE REGULATIONS.** 1913. 4d. (5d.)
- TRANSPORT MANUAL.** Field Service. 1905. Part I. Provisional. 4d. (4d.)
- TRANSPORT. MECHANICAL:—**  
Heavy Pontoon Bridge for use by. Provisional. 1914. 2d. (2d.)  
Regulations for the Appointment of Inspectors of. 1d. (1d.)
- TRANSPORT. PACK.** Notes on. 1d. (1d.)
- TRUMPET AND BUGLE SOUNDS** for the Army. With Instructions for the Training of Trumpeters and Buglers. 1914. 9d. (8d.)
- TYPHOID (ANTI-) COMMITTEE.** Report. 1912. 2s. 6d. (1s. 11d.)
- TYPHOID (ANTI-) INOCULATION COMMITTEE.** Report on Blood Changes following Typhoid Inoculation. 1905. 1s. 6d. (1s. 2d.)
- URDU-ENGLISH PRIMER.** For the use of Colonial Artillery. 1899. 15s. (10s. 2d.)
- VALISE EQUIPMENT.** Instructions for Fitting:—  
Pattern 1888 with pattern 1894 Pouch opening outwards. 1895. 1d. (1d.)  
Bandolier pattern. 1903. 2d. (2d.)
- VALPARAISO.** The Capture of, in 1891. 1s. (10d.)
- VENEREAL DISEASE.** See Medical Services.
- VETERINARY CORPS.** Army:—  
Regulations for Admission. 1910. 2d. (2d.)  
Standing Orders. 1906. 4d. (4d.)
- VETERINARY SERVICES.** Army. Regulations. 1906. (Reprinted, with Amendments to Dec. 1, 1914). 3d. (3d.)
- VOLUNTARY AID.** See Territorial Force.
- WAR OFFICE LIST, AND ADMINISTRATIVE DIRECTORY FOR THE BRITISH ARMY.** 1914. Sold by Harrison & Sons, 45, Pall Mall. 5s. net. (Under revision)
- WARFARE.** See Land Warfare.
- WATER SUPPLY MANUAL.** 1s. 6d. (1s. 4d.)
- WORKS MANUAL. (WAR).** 1913. 4d. (4d.); Appendix I. 1d. (1d.)
- X-RAY APPARATUS.** Hints Regarding the Management and Use of. 3d. (3d.)
- YEOMANRY AND MOUNTED RIFLE TRAINING.** Parts I. and II. 1912. 6d. (6d.)
- ZULU WAR OF 1879.** Narrative of the Field Operations connected with the. 1881. (Reprinted 1907.) 3s. (2s. 4d.)

**LMC**

SCANNED  
DECEMBER  
2010

**LAUGHTON MANAGEMENT CORPORATION**

582 Hawthorne Crescent, Milton Ontario CANADA L9T 4N8

Phone: (905) 878-1701    Fax: (905) 878-8775    Cell: (416) 219-6950  
Web: [www.censol.ca/lmc/](http://www.censol.ca/lmc/)    E-mail: [lmc@censol.ca](mailto:lmc@censol.ca)    TelNic: [lmc.laughton.tel](tel:lmc.laughton.tel)